



SP-50

REMOTE PULPER



The **Somat SP-50 Pulper** is one part of a Remote Pulping System. Pictured is a Hi-Tank pulper with optional water flushed tray and cover. This example also features a trough mount providing two feeds into one pulper. Below the tray feed is the slurry pump. The main benefits of a Somat Remote Pulping System are **Reduction** and **Transportation**. A remote system connects food prep and scrapping areas together through a series of piping and transports food service waste to a remote extractor. The extractor removes the solids (pulp) and recirculates the water back to the grinding tanks. The pulping process provides an 8 to 1 volume reduction (up to 85%.) The pulp is fed into a Somat Dehydrator for additional reduction or directly into a dumpster. A remote pulping system can eliminate the need for trash cans, liners and laborers to "take out the trash".

CAPACITY

900 pounds per hour of foodservice waste mix, consisting of food scraps, plastics, milk cartons, paper, aluminum foil and cardboard

TECHNICAL SPECIFICATIONS

Pulper:

- 23" diameter, 39" high polished stainless steel tank with water flushed feed tray
- Hinged lid with limit switch
- 3/8" thick stainless steel slurry chamber
- 5 HP TEFC direct drive motor
- internal junk box and cutting mechanism
- HyPoint cutting mechanism, stainless steel, consists of 1 piece security ring with 3 stationary, replaceable top cutters and impeller with 2 replaceable rotating cutters.

Valve Package:

- All valves required for proper operation (fresh water, tray flush and drain lines).

Som-A-Trol Electrical Control Panel:

- UL approved stainless steel NEMA 4 panel with all components pre-wired to internal terminal strip. Push Button control station on panel door (remote control station optional). Panel to be wall mounted with field connection to pulper mounted junction box.

OPTIONS

- Feed trough connection
- Feed tray cover
- Prison package
- Under dish table unit

Special Requirements:

- Dual water level control and motor operated valve with controls. Required if more than one pulper operating with a single Hydra-Extractor.
- Stainless Steel Dam. Required when pulper is located higher (one level minimum) than the Hydra-Extractor.

Voltage Options:

- 208/60/3
- 230/60/3
- 460/60/3
- International options available, consult factory

FINISH

All exterior surfaces are polished stainless steel.

The Power to Transform WASTEFUL to SUSTAINABLE

SP-50

REMOTE PULPER

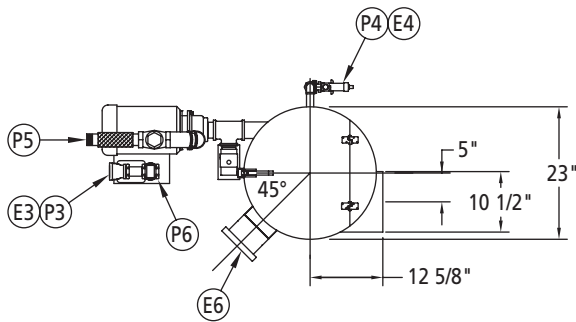

SP-50S (W/ 9" TANGENTIAL TROUGH ADAPTER)
MULTIPLE REMOTE ELEVATION VIEW

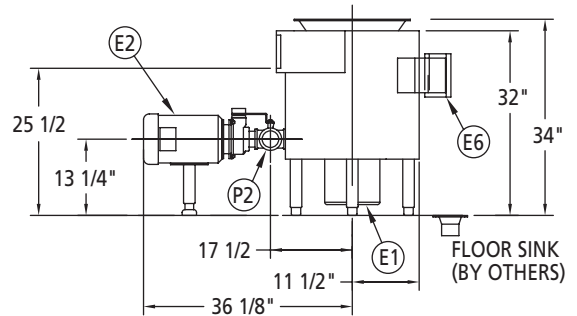

TYPICAL ELEVATION VIEW SP-50 UDT PULPER

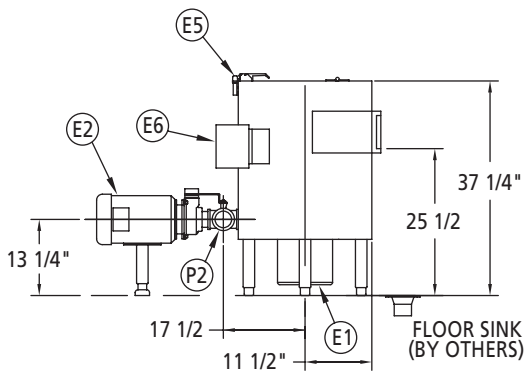

SP-50S (W/ 9" TANGENTIAL TROUGH ADAPTER)
MULTIPLE REMOTE ELEVATION VIEW

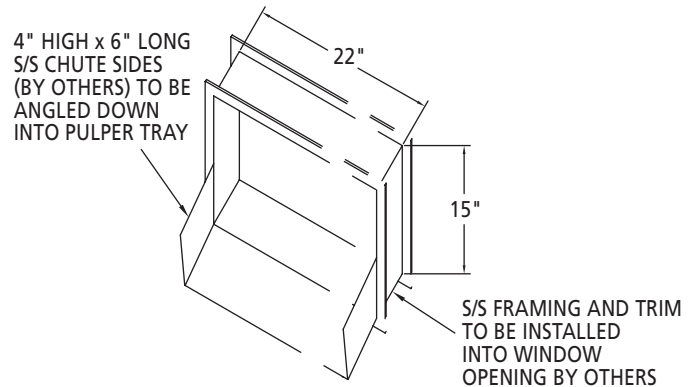

TYPICAL PASS THRU WINDOW DETAIL

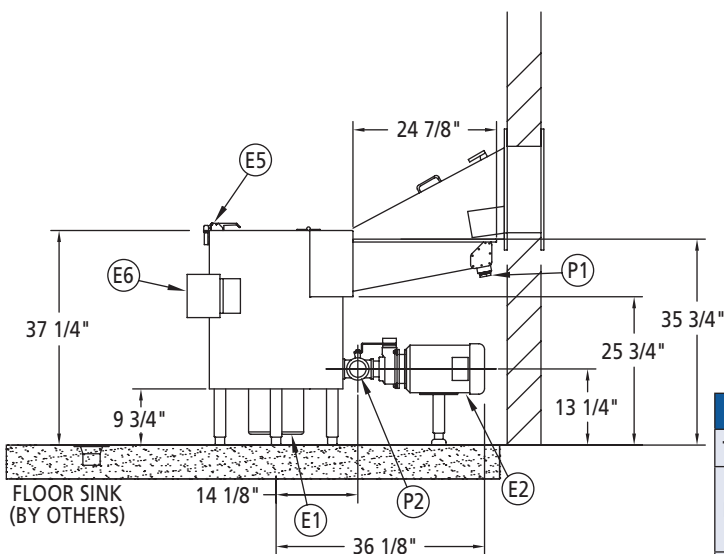

SP-50S (W/ TRAY FEED ADAPTER)
OPTIONAL PASS THRU WINDOW
ELEVATION VIEW

REMOTE UTILITY CONNECTION INFO

E1	Pulper Drive Motor	P1	Feed Tray Inlet
E2	Slurry Pump Motor	P2	Drain Valve Outlet
E3	Return line MOV	P3	Return Water Outlet
E4	Fresh Water Solenoid	P4	Fresh Water Inlet
E5	Lid Limit Switch	P5	Slurry Outlet
E6	Junction Enclosure	P6	Stand Pipe

DIMENSIONS – HIGH TANK

Tank Height	37 1/4" (946mm)	Equipment Weight	525 lbs. (238kg)
Length	53" (1346mm) (Excluding tray/trough)	Operating Weight	745 lbs. (338kg)
Width	23" (584mm) (Excluding external piping)	Crated Weight	850 lbs. (386kg)
		Crated Volume	85 cu. ft.

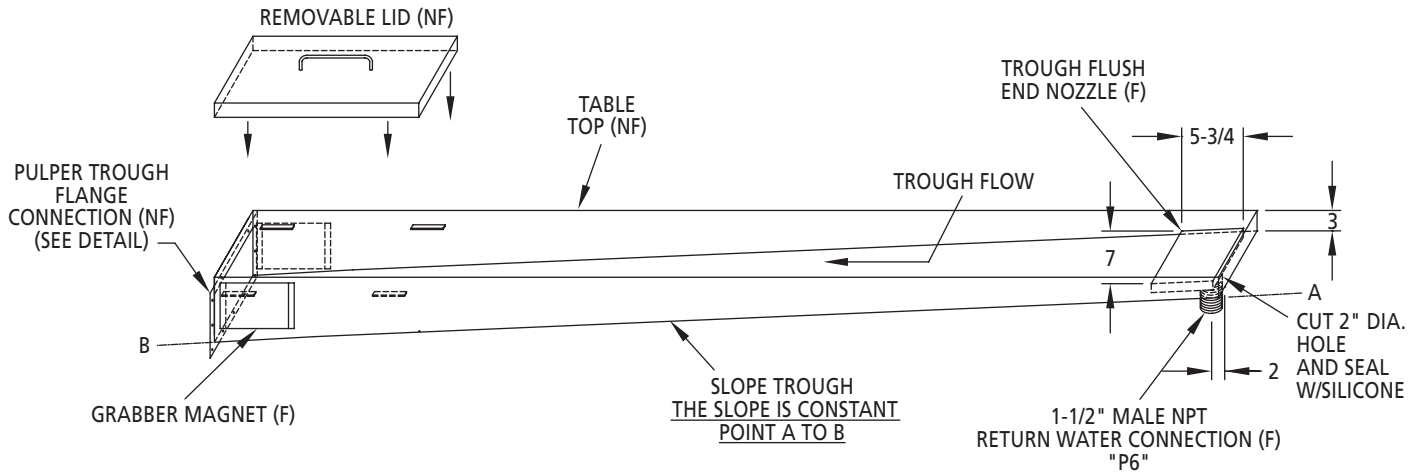

PULPER TROUGH DETAIL

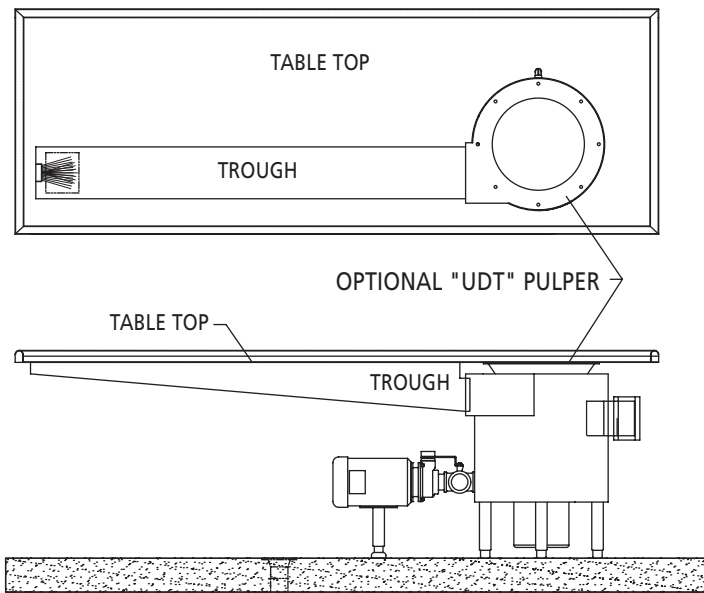
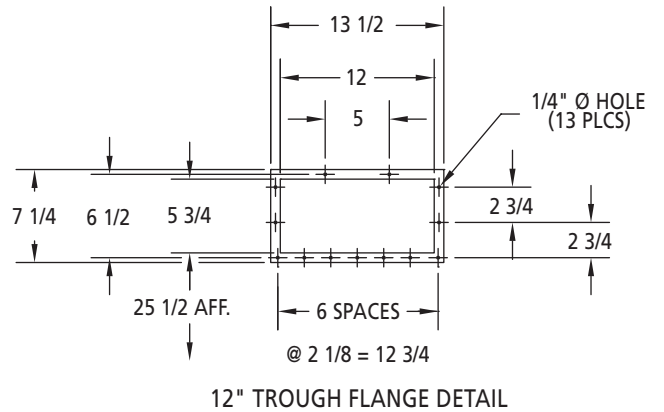
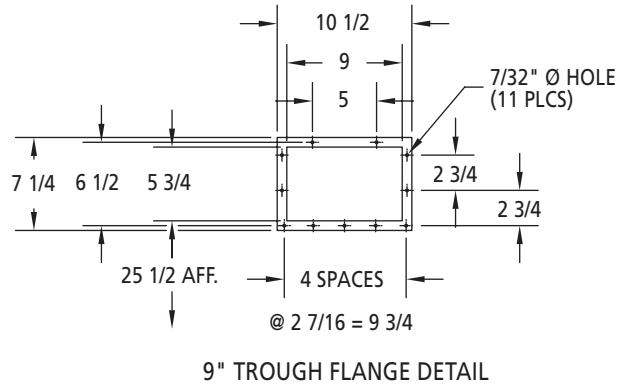
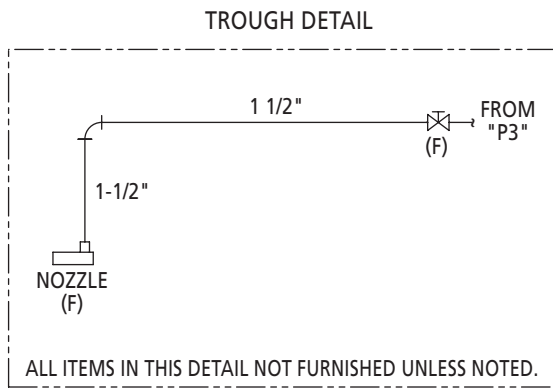

DIMENSIONS - UDT TANK			
Tank Height	32" (813mm)	Equipment Weight	525 lbs. (238kg)
Length	53" (1346mm) (Excluding tray/trough)	Operating Weight	745 lbs. (338kg)
Width	23" (584mm) (Excluding external piping)	Crated Weight	850 lbs. (386kg)
		Crated Volume	85 cu. ft.

SP-50 REMOTE PULPER

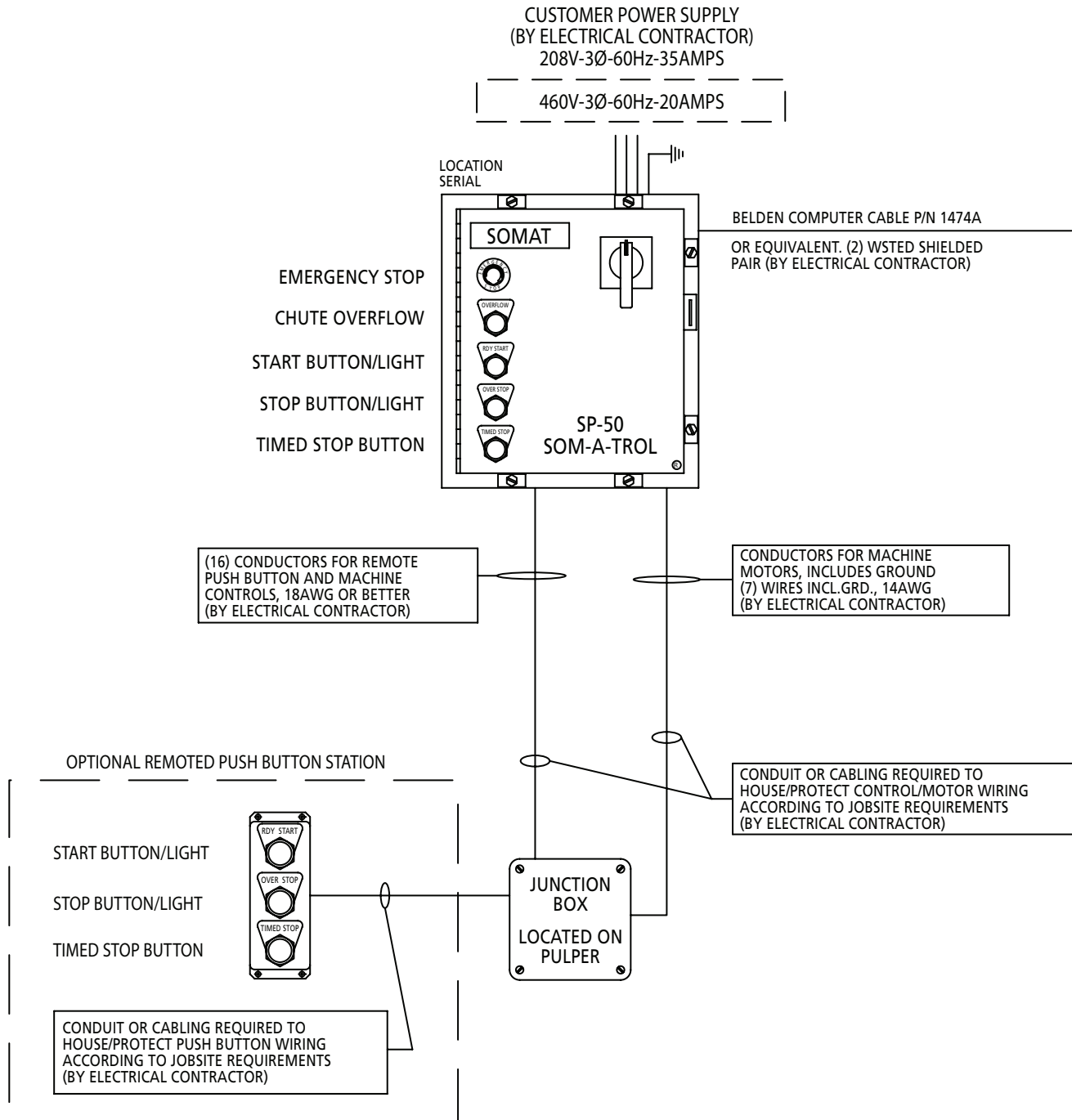

OTHER UTILITY REQUIREMENTS	
Fresh Water	6 gpm @ 30 psig, 3/4" NPT (approximate usage 60 gph)
Drain	3" minimum floor sink, 4" recommended (with stainless steel removable basket recommended)

In line with its policy to continually improve its products, Somat reserves the right to change materials and specifications without notice.