



INSTALLATION * OPERATION * MAINTENANCE



MANUAL FOR UNITS WITH SERIAL NUMBERS MD-6000 AND ABOVE
ALSO INCLUDES SERIAL NUMBERS 103000000 AND ABOVE

MASTER DISPOSERS

165 Independence Ct

Lancaster, PA 17601 USA

800-237-6628 , 717-397-5100 , Fax 717-299-4131

www.masterdisposers.com

Ordering Instructions	2	Maintenance	11
Safety	3	“F” Replacement Parts	12
General Installation	4	“C” Replacement Parts	14
“F” Series Installation & Connection	5	“B” Replacement Parts	16
“C” Series Installation & Connection	6	“RAC1” Replacement Parts	18
“B” Series Installation & Connection	7	“RAC2” Replacement Parts	19
Typical Installation/Startup & Run	8	Terms of Sale and Warranty	20
Operation Troubleshooting	9		
Troubleshooting	10		

ORDERING INSTRUCTIONS:

Contact the Factory-Authorized Parts Distributor for all parts orders or contact us directly for the name and phone number of the parts distributor nearest to you:

Call Toll Free: 800-237-6628 x 173

Fax: 717-299-4131

SAVE THESE INSTRUCTIONS!

Keep this booklet in a convenient location for future reference.

SAFETY



RECOGNIZE SAFETY INFORMATION. When you see this symbol on your machine or in this manual, be alert to the potential for personal injury.

UNDERSTAND SIGNAL WORDS. **DANGER**, **WARNING** and **CAUTION** appear with the safety-alert symbol in this manual and on safety labels on the machine to identify the level of hazard seriousness.

DANGER indicates a hazard that WILL result in severe personal injury or death.

WARNING indicates a hazard or unsafe practice which COULD result in severe personal injury or death.

CAUTION indicates a hazard or unsafe practice which COULD result in minor personal injury or equipment damage.



READ ALL INSTRUCTIONS

Read this owner's manual before using the machine. Failure to follow the instructions provided could result in personal injury or equipment damage.

KEEP OUT OF REACH OF CHILDREN

This disposer is intended for commercial use only.

THIS APPLIANCE IS NOT INTENDED FOR USE BY PERSONS (INCLUDING CHILDREN) WITH REDUCED PHYSICAL, SENSORY OR MENTAL CAPABILITIES, OR LACK OF EXPERIENCE AND KNOWLEDGE, UNLESS THEY HAVE BEEN GIVEN SUPERVISION OR INSTRUCTION CONCERNING USE OF THE APPLIANCE BY A PERSON RESPONSIBLE FOR THEIR SAFETY.



DISPOSER MUST BE PROPERLY INSTALLED WITH A HOPPER/CONE OR SINK ATTACHMENT TO PREVENT SERIOUS INJURY FROM MOVING SHREDDER PARTS.

DO NOT PUT HANDS OR ANY IMPLEMENT IN THE DISPOSER WHILE IN OPERATION. NEVER FEED WASTE BY HAND PAST VINYL SILVER TRAP SCRAPPING RING. DO NOT OPERATE IF DAMAGED.

Do not install or operate this disposer if the disposer has been dropped or damaged in any manner. Contact the nearest factory-authorized service center for examination, repair or adjustment. (Refer to the service center list included in the Owner's Information Packet.)

DO NOT LEAVE THE DISPOSER UNATTENDED

SET THE POWER SWITCH TO OFF BEFORE CLEARING JAMS OR REMOVING OBJECTS FROM THE DISPOSER.

When the disposer wiring is wired to a Manual Control or Model RAC1 Control Center, SHUT OFF the branch circuit main switch or disconnect.

Use long-handled tongs or pliers to remove objects.

TO REDUCE THE RISK OF INJURY BY MATERIALS THAT MAY BE EXPELLED BY THE DISPOSER, DO NOT PUT THE FOLLOWING INTO THE DISPOSER: drain cleaner, glass, china or plastic, large whole bones, metal (bottle caps, tin cans, aluminum foil, etc.), whole cornhusks.

ALWAYS KEEP VINYL SILVER SAVER TRAP SCRAPPING RING OR SINK STOPPER IN PLACE ON SERIES "F", EVEN WHEN NOT IN USE.

This reduces the risk of objects falling into the disposer.

WHEN CLEANING THE KITCHEN AND DISPOSER AREA, ONLY DAMP WIPE THE EXTERIOR OF DISPOSER AND CONTROLS. DO NOT AT ANY TIME HOSE DOWN THE EXTERIOR SURFACES OF THE DISPOSER AND CONTROLS.



GENERAL INSTALLATION

FABRICATING

1. Consult installation and connection data and installation diagrams on following pages for regular cone or sink attachment dish table cutout sizes.
2. For cone attachment, position cone so water swirl inlet fitting is nearest to operator.
3. Weld the total circumference of cone or sink attachment to prevent leakage.
4. Smooth grind and polish to match and blend weld seams.

NOTE: DO NOT PLACE CONTROL MOUNTING BRACKETS IN DIRECT WATER SPLASH AREAS.

PLUMBING

1. Consult installation and connection data and installation diagrams on following pages for mounting, hookups and pipe sizes.
2. "F" Series is mounted by suspending from dish table.
3. "B" and "C" Series use a floor leg support system with a neoprene connecting sleeve and two (2) stainless steel clamps. Supplied sleeve (9" length) should be cut to required length for connection of disposer to dish table.
4. Slide in, or position, disposer to connect to waste line, avoiding as many bends, elbows and tees as possible.
5. Perform power-rotor reaming of waste line whether connection is made to a new or old waste line. New lines often contain foreign items left in the lines accidentally during construction.
6. Blow new water feed lines out before connections are made. Dirt, solder, or other foreign matter can lodge itself in the flow controls, solenoid valve and vacuum breaker, causing malfunction.
7. Install solenoid valve. Check that inlet and outlet ports are in proper direction.
8. Check that the disposer and dish table opening are in line, level and true. This is visible when neo-prene sleeve is not kinked or partially collapsed. If level and in line adjustment is required, turn feet on bottom of legs.
9. Secure disposer to the floor using the holes provided in the feet.

ELECTRICAL

NOTE: FOLLOW GUIDELINES SET FORTH BY NEC STANDARD AND LOCAL CODES.

1. Consult installation and connection data and diagrams on following pages for control placement and motor wiring.

NOTE: DO NOT PLACE CONTROL IN DIRECT WATER SPLASH AREAS

2. Follow supplied wiring schematics for all controls, solenoid valves and pre-wired custom control centers.
3. Size and fuse disposer branch circuit or use circuit breakers as required by motor nameplate rating.
4. Check that motor voltage wiring matches incoming voltage.

NOTE: ALL CONDUIT AND FITTINGS SHALL BE OF THE NEMA 4 WATERTIGHT TYPE.

5. Disposers that have thermal protection of the manual reset type, in motor. Check that the reset button is not jammed.
6. Disposers that do not have thermal protection in motor must have thermal protection (heaters) in control.
7. Check that all connections are tight, secure and well-grounded.

NOTE: Disposers are designed to operate in both a clockwise and counter-clockwise direction. Direction of rotation does not have to be considered when wiring a motor.

GROUNDING

Connect disposer to a grounded metal permanent wiring system or run a disposer grounding conductor with the circuit conductors and connect it to the disposer grounding terminal or lead on the disposer.

"F" SERIES - INSTALLATION & CONNECTION

NOTE: PLUMBING AND ELECTRICAL CONNECTIONS SHALL BE MADE IN COMPLIANCE WITH APPLICABLE LOCAL CONSTRUCTION CODES.

PLUMBING

Inlet: Cold water supply to disposer shall be 1/2" service line with a minimum of 20lbs. Flow pressure, piped as close to disposer as possible. All disposer and control connections shall be 1/2" pipe sizes.

Sewer Outlet: 1-1/2" waste line should have trap with conveniently located clean out. *Do not connect through a grease trap!* Avoid bends, elbows, tees, etc., to reduce the possibility of plumbing stoppages. A globe valve, used for metering flow, must be installed between the solenoid valve and the cone or sink. Water swirl inlet valves should be located nearest operator.

See Typical Installation Diagram.

ELECTRICAL

Follow guidelines set forth by NEC standards. Disposer branch circuit shall be sized and fused (circuit breakers) as required by motor. The disposer must be connected to a grounded, metal, permanent wiring system; or a disposer-grounding conductor must be run with the circuit conductors and connected to the disposer-grounding terminal or lead on disposer. All connections, junction boxes and conduits must be watertight (NEMA 4).

TESTING - See Startup and Run Section

INSTALLATION DIAGRAM

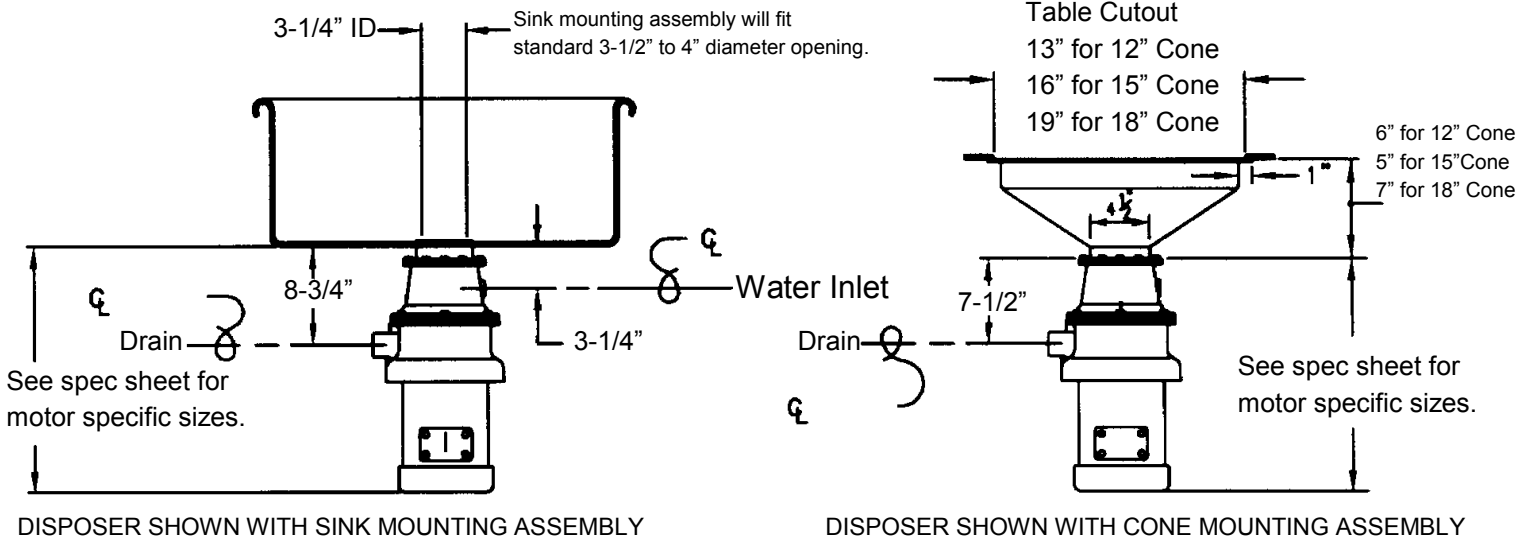

MOTOR WIRING DIAGRAM

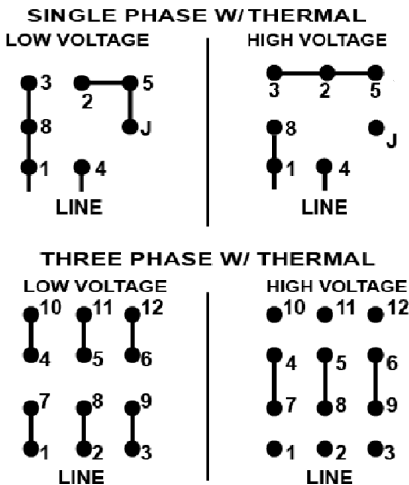

VOLTAGE-AMPERAGE TABLE

HP	THREE PHASE		THREE PHASE		SINGLE PHASE		SINGLE PHASE	
	Volts/60Hz	Amps	Volts/50Hz	Amps	Volts/60Hz	Amps	Volts/50Hz	Amps
0.5	208	2.5	208	2.6	115	4.6	110	6.8
	230	2.4			230	2.3	220	3.4
	460	1.2	415	1.3				
0.75	208	2.6	208	2.6	115	6.3	110	8.2
	230	2.4			230	3.15	220	4.1
	460	1.2	415	1.3				
1.25	208	3.7	208	4	115	11.1	110	12.8
	230	3.6			230	5.05	220	6.4
	460	1.8	415	2				

"C" SERIES - INSTALLATION & CONNECTION

NOTE: PLUMBING AND ELECTRICAL CONNECTIONS SHALL BE MADE IN COMPLIANCE WITH APPLICABLE LOCAL CONSTRUCTION CODES.

PLUMBING

Inlet: Cold water supply to disposer shall be 1/2" service line with a minimum of 20lbs. Flow pressure, piped as close to disposer as possible. All disposer and control connections shall be 1/2" pipe sizes.

Sewer Outlet: 2" waste line should have trap with conveniently located clean out. *Do not connect through a grease trap!* Avoid bends, elbows, tees, etc., to reduce the possibility of plumbing stoppages. A globe valve, used for metering flow, must be installed between the solenoid valve and the cone or sink. Water swirl inlet valves should be located nearest operator.

See Typical Installation Diagram.

ELECTRICAL

Follow guidelines set forth by NEC standards. Disposer branch circuit shall be sized and fused (circuit breakers) as required by motor. The disposer must be connected to a grounded, metal, permanent wiring system; or a disposer-grounding conductor must be run with the circuit conductors and connected to the disposer-grounding terminal or lead on disposer. All connections, junction boxes and conduits must be watertight (NEMA 4).

TESTING - See Startup and Run Section

INSTALLATION DIAGRAM

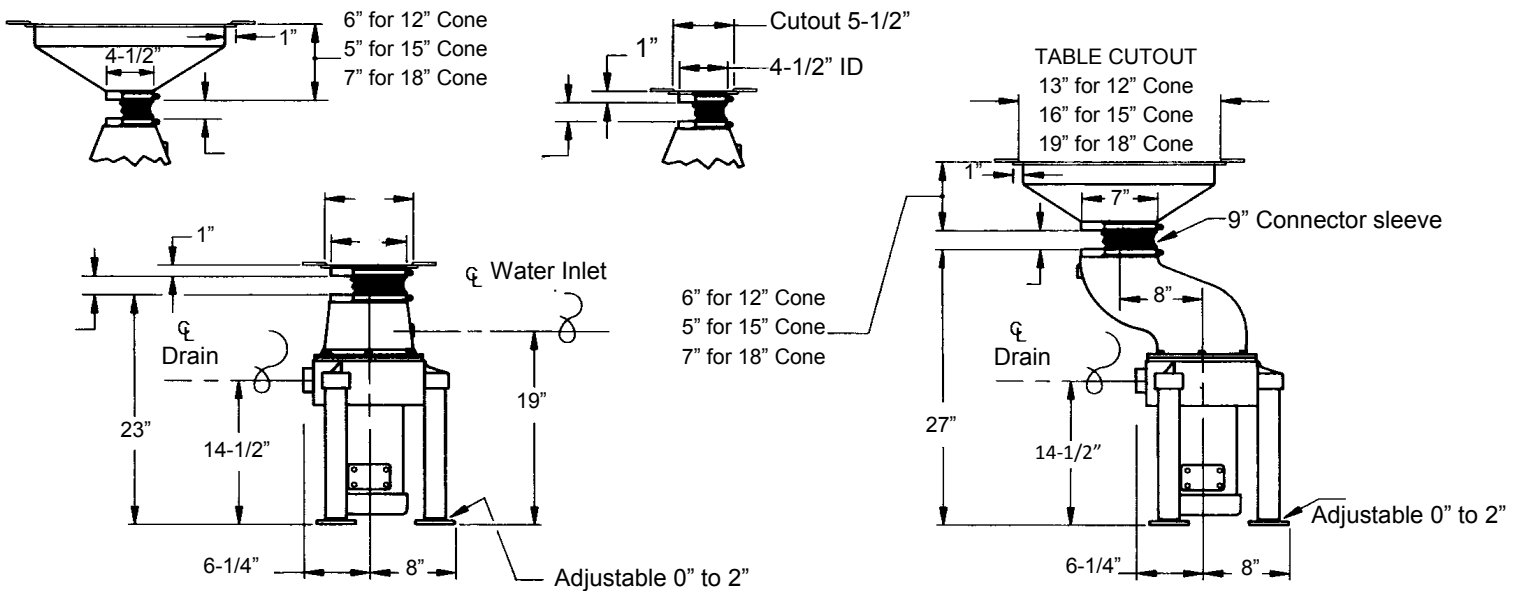

MOTOR WIRING DIAGRAM

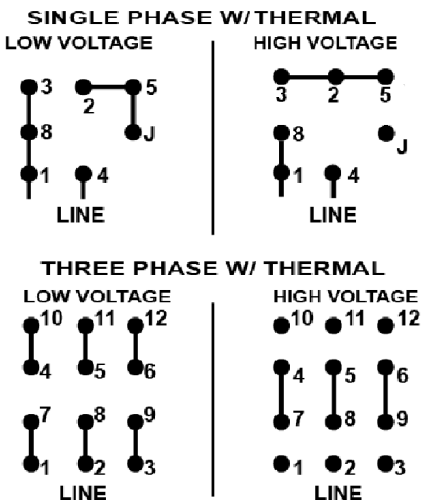

VOLTAGE-AMPERAGE TABLE

HP	THREE PHASE		THREE PHASE		SINGLE PHASE		SINGLE PHASE	
	Volts/60Hz	Amps	Volts/50Hz	Amps	Volts/60Hz	Amps	Volts/50Hz	Amps
1.5	208	4.4	208	4.8	115	16	110	15
	230	4.2			230	8	220	7.5
	460	2.1	415	2.4				
2	208	6	208	6.3	115	17.6	110	19
	230	5.8			230	8.8	220	9.5
	460	2.9	415	3.3				
3	208	9.9	208	10.4				
	230	9			N/A		N/A	
	460	4.5	415	5.2				
5	208	14.8						
	230	14	N/A		N/A		N/A	
	460	7						

"B" SERIES - INSTALLATION & CONNECTION

NOTE: PLUMBING AND ELECTRICAL CONNECTIONS SHALL BE MADE IN COMPLIANCE WITH APPLICABLE LOCAL CONSTRUCTION CODES.

PLUMBING

Inlet: Cold water supply to disposer shall be 1/2" service line with a minimum of 20lbs. Flow pressure, piped as close to disposer as possible. All disposer and control connections shall be 1/2" pipe sizes.

Sewer Outlet: 2" waste line should have trap with conveniently located clean out. *Do not connect through a grease trap!* Avoid bends, elbows, tees, etc., to reduce the possibility of plumbing stoppages. A globe valve, used for metering flow, must be installed between the solenoid valve and the cone or sink. Water swirl inlet valves should be located nearest operator.

See Typical Installation Diagram.

ELECTRICAL

Follow guidelines set forth by NEC standards. Disposer branch circuit shall be sized and fused (circuit breakers) as required by motor. The disposer must be connected to a grounded, metal, permanent wiring system; or a disposer-grounding conductor must be run with the circuit conductors and connected to the disposer-grounding terminal or lead on disposer. All connections, junction boxes and conduits must be watertight (NEMA 4).

TESTING - See Startup and Run Section

INSTALLATION DIAGRAM

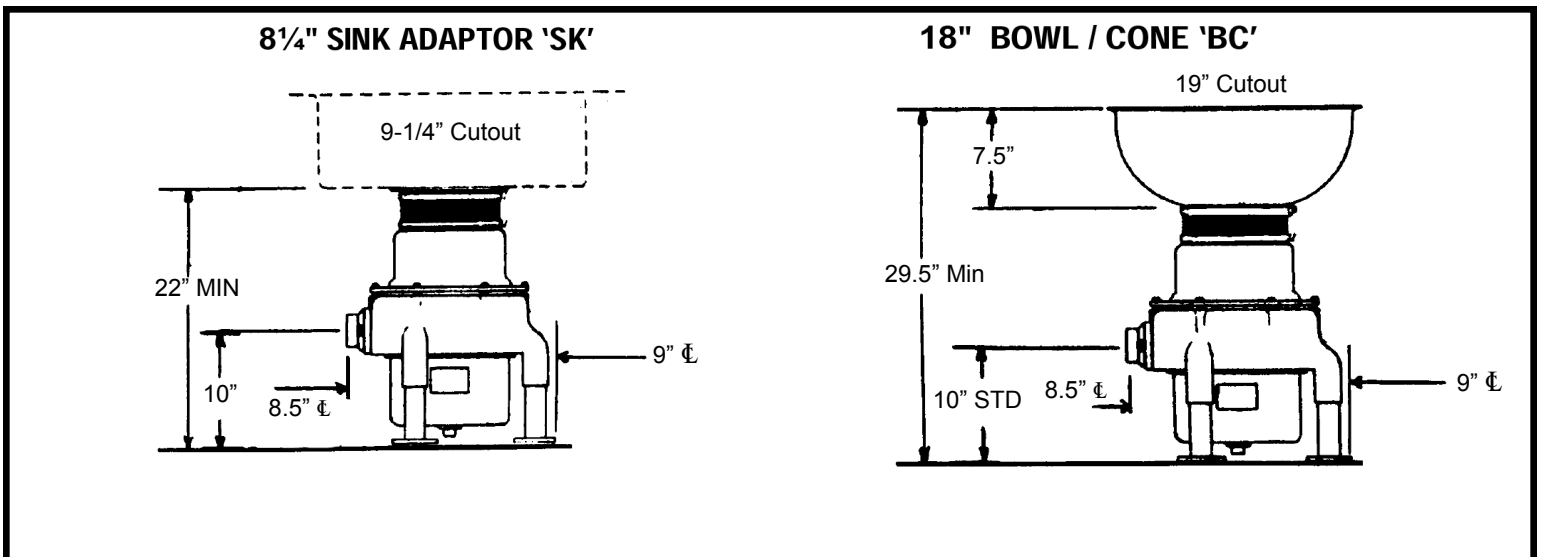

THREE PHASE W/O THERMAL

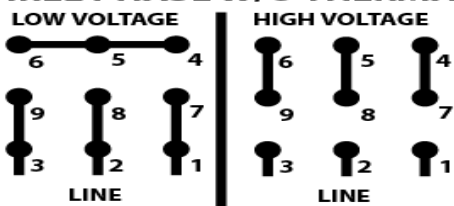

INTERCHANGE ANY TWO LINE WIRES TO REVERSE ROTATION

THREE PHASE W/ THERMAL

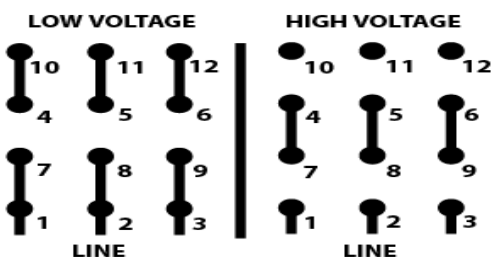

TO REVERSE ROTATION INTERCHANGE ANY TWO LINE WIRES

VOLTAGE-AMPERAGE TABLE

HP	THREE PHASE		THREE PHASE	
	Volts/60Hz	Amps	Volts/50Hz	Amps
3	208	9.5	208	10.6
	230	9.2		
	460	4.6	415	5.3
5	208	14.5	208	19.4
	230	14		
	460	7.5	415	9.7
7.5	208	23		
	230	22	N/A	N/A
	460	11		
10	208	30		
	230	28	N/A	N/A
	460	14		

TYPICAL INSTALLATION

8¹/₄" SINK ADAPTOR 'SK'

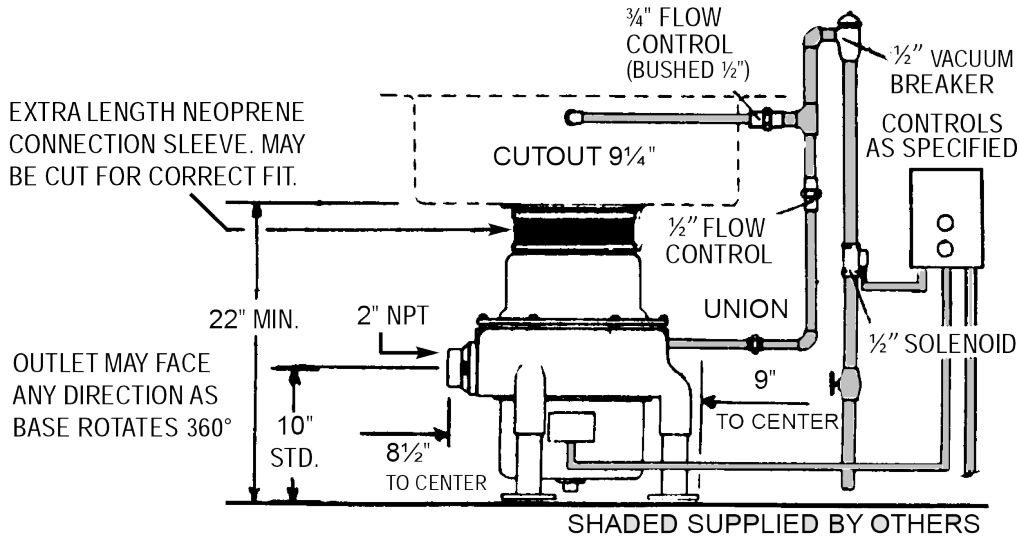

STARTUP AND RUN CHECK

1. Check that vinyl silver trap scrapping ring is fully seated.
2. Check that all connections are secure.
3. Check that the disposer is secured to the floor.
4. Open terminal wiring box on motor; pull out and separate motor leads to permit amperage reading on each leg. Leave all connections and insulation in place.
5. Clamp ammeter over input feed lead.
6. Turn on disposer.
7. Check for leaks, water flow, excessive noise or vibration, and regulate water flow if required.
8. Take ampere readings on each leg and verify against factory-checked motor test results.

NOTE: Before checking rotation reversal, be sure disposer is empty. Wear safety goggles or glasses. BE SURE POWER SWITCH IS OFF SHOULD ADJUSTMENTS ON DISPOSER BE NECESSARY. NEVER REACH INTO DISPOSER WHEN DISPOSER IS RUNNING.

9. If disposer is connected to a reversing control, whether automatic or manual, check reversing.
10. If disposer is connected to a manual reversing drum switch or contactor, START motor in forward position and note rotation through top opening as motor coasts to a stop. RESTART motor in reverse position. Verify that the disposer restarted in opposite direction.
11. If disposer is connected to a control center with automatic reversing (Model RAC1/RAC2), verify if disposer reverses.

NOTE: Motor must be stopped or 30 seconds must have elapsed before pushing START; otherwise, motor will not reverse. This is a safety cycle feature. Should START be pressed prior to elapsed time, motor will run in same direction. Direction Test: A.) Press Start-Disposer Run. B.) Press Stop (note coast down direction). C.) Wait 30 sec. after motor stops. D.) Press Start-disposer should run in opposite direction.

12. If disposer is wired with a RAC1 or RAC2, there are 3 trim-pots on the Control Module inside the controller that adjust operation (to enable or disable clean-out cycles). For more information about this Eco-Mizer: Electricity and Water Saver, please see the instructions for Adjustable Timer with Auto Shut-Down spec sheet in the control box. This timer is used to control the shut-down sequence of industrial garbage disposal units. When either the stop input is activated or the Auto Shut-Down timer times out, the two stage shut-down sequence begins. The first stage is Clean Out, where *both* the motor and water flow continue for up to 2 minutes. The second stage is a positive flush, where the motor is stopped, but the water flow is continued, also for up to 2 minutes. The disposal may be restarted at any time, but if the motor has been off for more than 30 seconds, its direction will be reversed.

13. In all shutdown phases, be sure water is being shut off by the closing of the solenoid valve.
14. Reinsert all wiring, close all covers and shut all doors that were open during the run check.

OPERATION

1. Check that the disposer is empty and clean from previous use.
2. Check that the vinyl trap scrapping ring is in place and properly seated over throat opening in cone or sink.
3. Turn disposer ON. Note that the water is flowing into top cone or into sink via the water swirl fitting.



WARNING: Never feed waste by hand past the vinyl silver trap ring or reach inside a running disposer.

NOTE: Do not feed metal, wood, cloth, rubber, corn husks, plastics, plastic sheets or bags, Styrofoam, or other foreign matter. A periodic clean out of such material from the disposer is advisable.

4. Proceed with dish cleanup, feeding waste gradually. DO NOT pack waste into the disposer waste chamber.
5. After each use, if disposer is wired with manual controls, allow disposer to run (motor and water) for at least 2 minutes. This clean-out cycle will empty the disposer and flush the waste line, preventing potential drain stoppage.
6. Should the motor stop during use cycle, SHUT POWER OFF IMMEDIATELY, via ON-OFF switch. If disposer is connected to a RAC2 Control Center, shut OFF power at the black emergency disconnect handle; on manual switches, turn branch circuit disconnect to OFF.

A. Remove vinyl silver scrapping ring and check waste chamber through top opening and remove foreign objects that may have caused stoppage.

B. Check to see if rotor turns freely.

C. If rotor turns freely, replace vinyl silver saver scrapping ring and turn disposer ON.

If disposer fails to start and run, an obstruction may still be binding the rotor.

A. Turn disposer OFF. Using a wooden bar or wooden handle, pry and push against the impact bars on the rotor to break it free; then remove the object.

B. Turn disposer ON and if motor fails to start, the thermal protector, either in the motor or in the controls may have tripped.

C. Push reset button on thermal protector.

If disposer still fails to start, check for blown fuses or tripped circuit breakers in the branch circuit (especially on three-phase installations) to be sure that all power legs are feeding motor.

TROUBLESHOOTING

DISPOSER DOES NOT START WHEN NEW

1. Manual reset button or thermal protector is tripped.
2. Fuses or circuit breaker on branch circuit feed line has tripped.
3. Electrical connection on motor, in panel or feed lines not tight.
4. Heaters have not been installed in starter, if starter is used in circuit.

DISPOSER DOES NOT START AFTER STANDING UNUSED FOR A PERIOD OF TIME

1. Clean cycle too short. When the disposer is stopped too early, the remaining water slowly drains out carrying the shattered waste particles into the very close clearance opening between the sizing ring and rotor, where it hardens and solidifies acting as a binding agent between the two parts. The motor at startup is unable to overcome the dried blockage.

DISPOSER STALLS WHEN IN OPERATION

1. Large quantities of foreign material (rags, wood pieces, rubber bands, strings, pieces from floor mops, cellophane and polyethylene) which will not disintegrate and will cause the motor to overheat and the thermal protector to trip.
2. Not enough water volume flow (GPM) causing thermal protector to trip.
3. Thermal protectors (heaters) sized too small, causing nuisance tripping.

TROUBLESHOOTING (continued)

DISPOSER OPERATES BUT DISINTEGRATION AND DISCHARGE IS SLOW

1. Not enough water volume flow (GPM).
2. Worn shattering mechanism (impact bars, sizing ring, rotor).
3. Large amounts of foreign material in waste chamber.

DISPOSER MOVES WHEN STARTED

1. Large amounts of unprocessed waste in chamber.
2. Rotor unbalanced due to loose impact bar.
3. Disposer not anchored to floor.

DRAIN LINE CLOGS

1. Worn shattering mechanism (impact bars, sizing ring, rotor) permitting large waste particles to flow through.
2. Large amount of paper and non-food particles being fed into disposer.
3. Not enough water volume flow (GPM).

DISPOSER DOES NOT TURN OFF (AFTER CLEAN OUT CYCLE, IF WIRED WITH RAC1 or RAC2)

1. Stop button in switch or control is defective.
2. Timer in control center is defective.

DISPOSER DOES NOT REVERSE

1. Contacts in manual reversing switch burned.
2. Contactor in auto reversing control center defective.
3. Reversing circuit in auto reversing control center defective.
4. Time lapse safety circuit in auto reversing control center defective.
5. Motor not wired as indicated in wiring diagram.

SEVERE VIBRATION DURING OPERATION

1. Loose or broken impact bars.
2. Unprocessed waste lodged in rotor.
3. Severe rotor damage from metal objects being fed into disposer.

MOTOR RUNS BUT NO WATER FLOW

1. Solenoid valve improperly wired.
2. Defective solenoid valve coil.
3. No water flow in main feed line.

MOTOR NOT TURNING AT PROPER RPM

1. Low voltage on incoming feed line.
2. On Three-Phase hookups, no voltage on one feeder line (leg).
3. Motor not wired as indicated in wiring diagram (low to high, high to low volts).

LOUD NOISE FROM MOTOR AREA

1. Upper or lower or both bearings worn
2. Leakage of disposer seals.

SMOKE OR BURNING ODOR FROM MOTOR

1. Incoming voltage not correct.
2. On Three-Phase hookups, no voltage on one feeder line (leg).
3. Water leaking into motor through faulty seals.
4. Disposer being overloaded, especially with foreign material.
5. Improper motor connections.

MOTOR BURNS OUT

1. Internal winding short.
2. Water leaking in motor through faulty seals.
3. Disposer being overloaded.
4. Incoming voltage incorrect.
5. Thermal protectors (heaters) not tripping, sized too large.

WATER SPLASHING UP FROM DISPOSER

1. Building water pressure too high.
2. Globe valve not installed or needs adjustment.

WATER FLOWS BUT MOTOR DOES NOT RUN

1. Thermal protectors (heaters) not installed in starter.
2. Motor not wired as indicated on wiring diagram.
3. Control not wired correctly

1. WATER LEAKING FROM BASE OF DISPOSER

2. Defective seals.
3. Hole worn in base.
4. Motor mounting screws not sealed on "C" series units.
5. Leaking plumbing connections or leaking sink mounts.

MAINTENANCE

Waste disposer troubles usually involve plumbing. A preventative maintenance program is advisable to keep waste line stoppages and disposer repairs at a minimum. Any sewer problem occurring shortly after your disposer has begun operation cannot be caused by the new machine. It will be the result of connecting to either inadequate waste line, or to one that has not been properly cleared before use. On the other hand, if waste line clogging occurs after the disposer has been running trouble-free for a year or more, this indicates a need for servicing.

The slurry leaving a new disposer contains no discernible solids, so there is nothing to clog the waste line. In regular use, however, wearing of the working parts is to be expected. As the gradual wear occurs, the solid particles passing through the wider gaps in the shatter mechanism will grow increasingly larger, until waste line stoppage may result.

MONTHLY WEAR CHECK

NOTE: The following should be performed every two weeks if waste is of a highly abrasive consistency.

1. Shut OFF branch circuit power, or emergency disconnect on control panel when disposer has completed its clean out cycle.
2. Loosen stainless steel clamps on neoprene connector sleeve.
3. Twist sleeve and remove.
4. Remove any foreign objects (rubber bands, metal, wood, plastics, etc.) from the waste chamber.
5. Check free movement of rotor.
6. The two points of probable wear are the leading edges of the impact bars and the spacing between the outer-edges of the rotor and the inner diameter of the sizing ring teeth.

F SERIES REPLACEMENT PARTS DIAGRAM

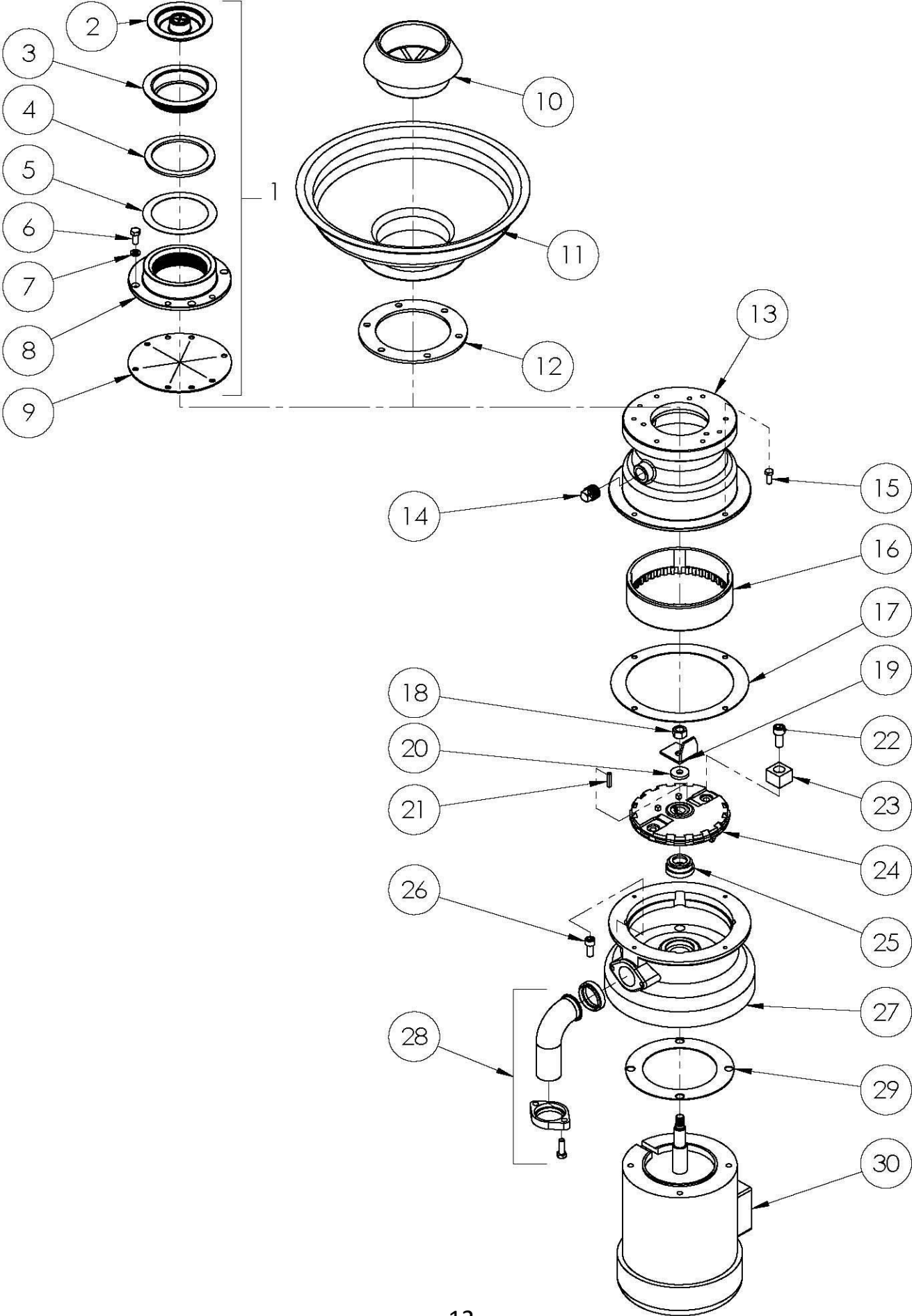

F SERIES REPLACEMENT PARTS LIST

KEY NO.	PART NO.	NAME: DESCRIPTION/	QTY PER MACH.
1	30-H-RSA	RSA Head Assy (includes 2-9)	1
2	06-H-8	Sink Stopper:	1
3	27-H-15	Sink Mount: Threaded	1
4	07-H-19	Gasket: RSA Rubber	1
5	07-H-20	Gasket: RSA Fiber	1
6	08-H-21	Screw, Hxhd 5/16-18 x 3/4	4
7	08-HA-311	Washer: Lock Split 5/16	4
8	51-H-17	RSA Head	1
9	07-H-18	Gasket: Splash Guard	1
10	06-HA-ST4	Silver Saver: 4 1/2"	1
11		Cone (See Catalog)	
12	07-H-34	Gasket: Cone	1
13	00-289006	Housing: Upper Short	1
14	FP-066-02	Pipe Plug: 1/2"	1
15	SC-036-13	Screw: Hxhd. 1/4-20 x 3/4	4
16	00-201227	Ring: Shredder	1
17	G-6814	Gasket: Waste	1
18	NS-031-39	Stop Nut: 1/2-20 "Elastic"	1
19	00-201235	Cutter: Hi-Bulk	1
20	00-272003	Sealing Washer	1
21	00-203619-00001	Key: Shaft	1
22	00-202556-00001	Screw: SKHDCAP	2
23	00-201223-00003	Cutter: Flywheel 1/2	2
	00-201223-00001	Cutter: Flywheel 3/4	2
	00-201223-00004	Cutter: Flywheel 1-1/4	2
24	00-201250-00001	Flywheel	1
25	07-HA-83	Cartridge Seal	1
	04-HA-263	Install. Tool: FA Cartridge Seal	1
26	08-5-24.	Screw: Skhd 3/8-16 x3/4 Nyloc SS	4
27	51-H-2014	Housing: Lower	1
28	HD-SFK	Kit: Spout & Flange	1
29	07-HA-5	Gasket: Motor/ Base	1

NOT SHOWN

00-289004-00001	Upper Housing & Shredder Ring Assy. (Incl. 6,7,13,14,16)
40-HA-507	Motor Seal Kit (Incl. 25 & 29)

MOTOR OPTIONS

30	F-001235060	Motor: 1/2HP/3PH/50 & 60HZ	1
	F-001215060	Motor: 1/2HP/1PH/50 & 60HZ	1
	F-003435060	Motor: 3/4HP/3PH/50 & 60HZ	1
	F-003415060	Motor: 3/4HP/1PH/50 & 60HZ	1
	F-011435060	Motor: 1-1/4HP/3PH/50 & 60HZ	1
	F-011415060	Motor: 1-1/4HP/1PH/50 & 60HZ	1

C SERIES REPLACEMENT PARTS DIAGRAM

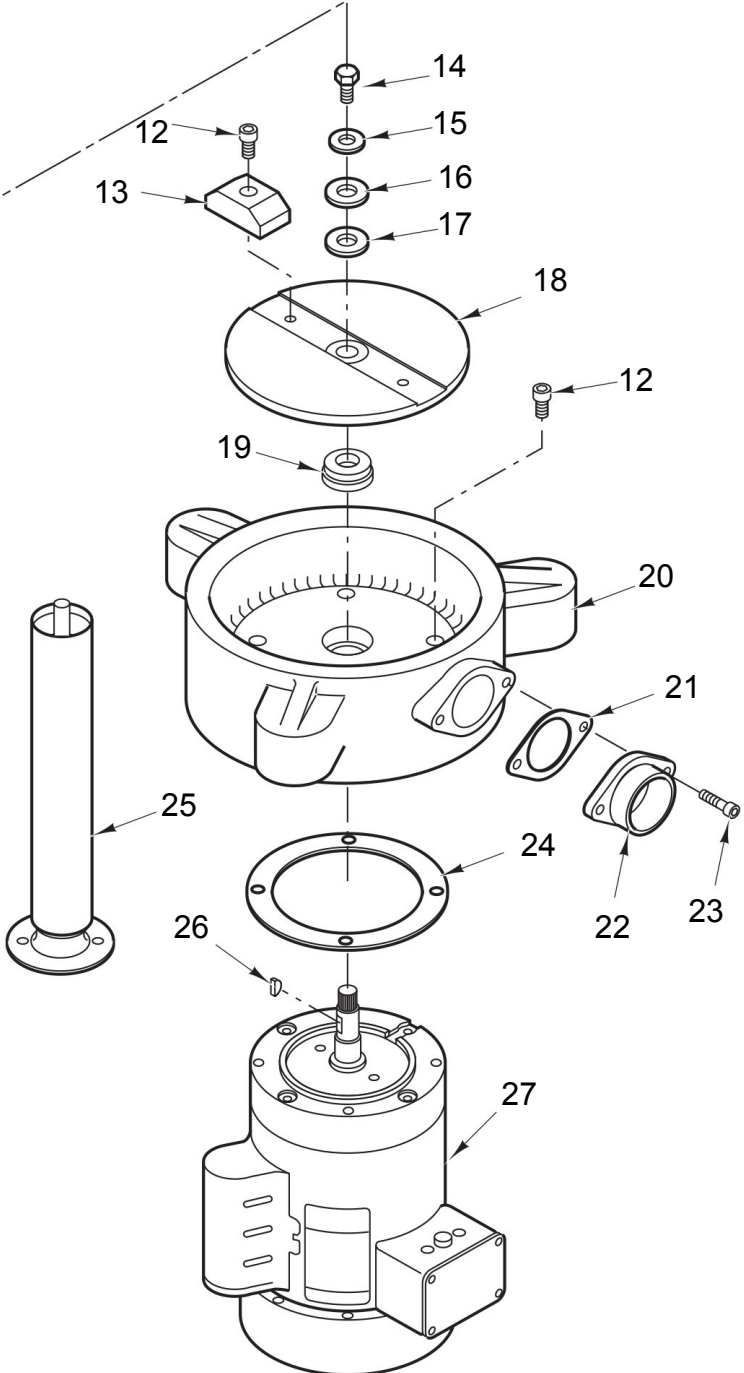
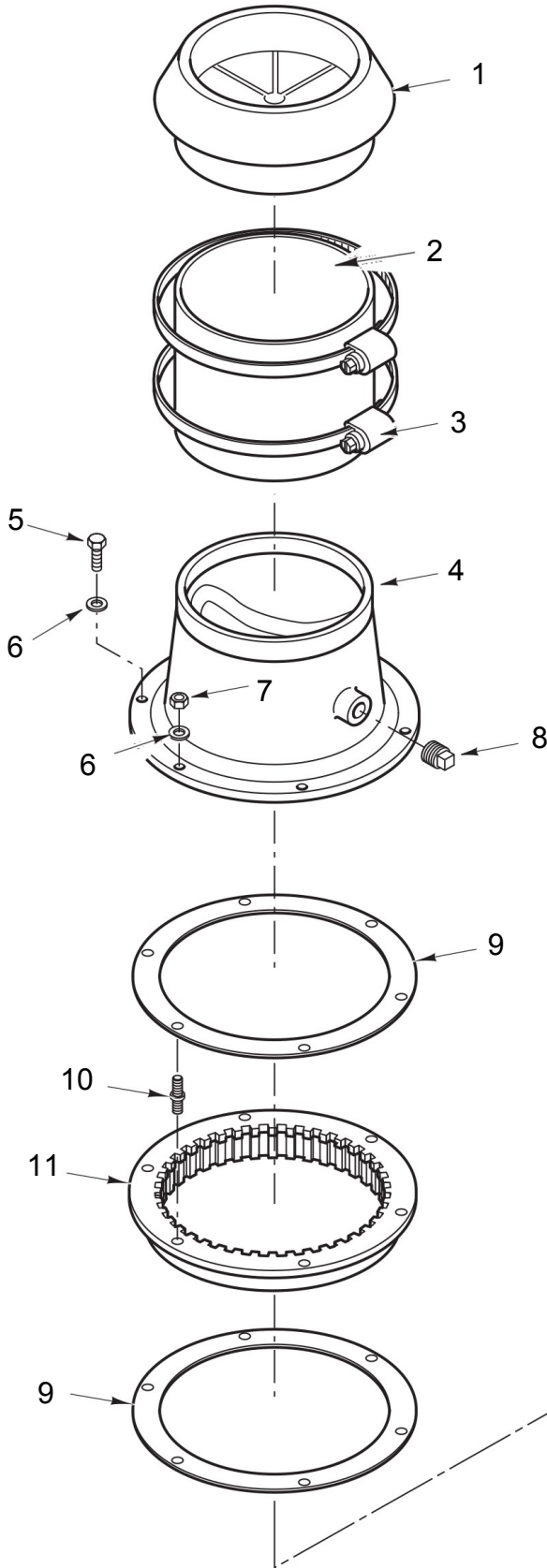
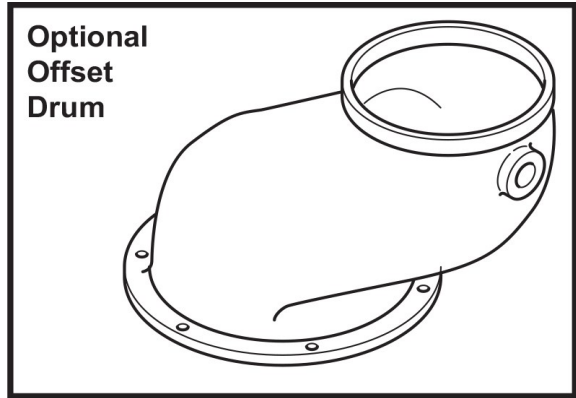

C SERIES REPLACEMENT PARTS LIST

KEY NO. PART NO. NAME: DESCRIPTION/ QTY PER MACH.

KEY NO. PART NO. NAME: DESCRIPTION/ QTY PER MACH.

1	H-391	Silver Saver Scrapping Ring	1
2	G-554	Neoprene Connector Sleeve	1
3	A-3000	Stainless Steel Clamps	2
4	51-A-11MD	Drum: 8 1/4" Throat	1
	51-A-81	Offset Drum: 7" Throat	1
5	08-HA-22	Screw: Hxhd 5/16-18 x 1, SS	4
6	08-HA-311	Washer: Lock Split 5/16	6
7	08-HA-17	Nut: Hex 5/16-18	2
8	10-5-27.	Pipe Plug: 1/2"	1
9	07-A-10	Gasket: Sizing Ring	2
10	08-HA-16	Centering Stud	2
11	30-A-9	Sizing Ring	1
12	08-5-24.	Screw: Skhd 3/8-16 x3/4 Nyloc SS	2
13	30-A-27	Impact Bar	2
14	08-H-21	Screw: Hxhd 5/16-18 x 3/4 SS Nyloc	1
15	08-HA-311	Washer: Lock Split 5/16	1
16	09-HA-2	Coverplate	1
17	07-HA-3	Gasket: Coverplate	1
18	51-A-1	Rotor	1
	30-A-1	Rotor Assy: w/Impact Bars (Includes 12, 13 & 18)	1
19	07-HA-83	Cartridge Seal	1
	04-HA-263	Install. Tool: HA Cartridge Seal	1
20	51-A-1141	Base	1
	30-A-1141	Base Assy. Includes Seal Includes Key No. 19, 20, 21, 22, 23	1
21	A-161	Gasket: Discharge Flange	1
22	A-159	Discharge Flange	1
23	A-4120	Screw: 7/16-20x1 S.H.C.S.	2
24	07-HA-5	Gasket: Motor/Base	1
25	09-A-928	Leg Assy w/Foot: 2" X 13.5, SS	3
26	02-HA-100	Key	1

MOTOR OPTIONS

27	D-011235060	Motor: 1.5HP/3PH/50 & 60HZ	1
	D-0112160	Motor: 1.5HP/1PH/60HZ	1
	D-0112150	Motor: 1.5HP/1PH/50HZ	1
	D-0235060	Motor: 2HP/3PH/50 & 60HZ	1
	D-02160	Motor: 2HP/1PH/60HZ	1
	D-02150	Motor: 2HP/1PH/50HZ	1
	D-0335060	Motor: 3HP/3PH/50 & 60HZ	1
	D-05360	Motor: 5HP/3PH/60HZ	1

NOT SHOWN

02-5-400	Bearing: #205 UPPER 1.5 & 2HP	1
02-HA-399	Bearing: #203 LOWER 1.5 & 2HP	1
02-BC-401	Bearing: #206 UPPER 3 & 5HP	1
02-5-400	Bearing: #205 LOWER 3 & 5HP	1
G-556-A	B/L Adaptor (to be used w/offset)	1
40-A-503	Complete Renewal Kit	1
40-A-1A	Rotor Kit (Includes 12-18)	1
40-A-9A	Sizing Ring Kit (Includes 6, 7 & 9-11)	1
40-HA-507	Motor Seal Kit (Includes 19 & 24)	1

B SERIES REPLACEMENT PARTS DIAGRAM

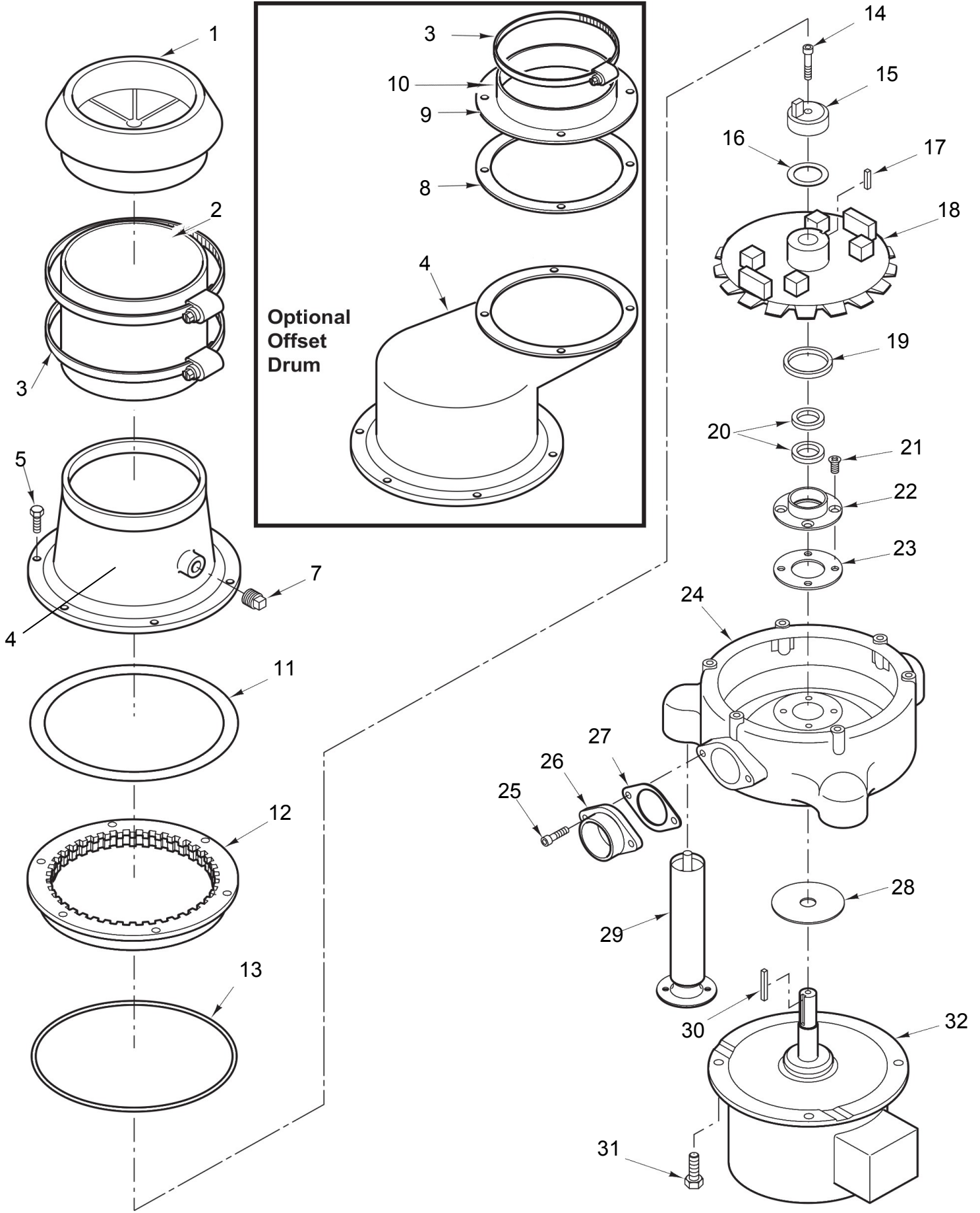

B SERIES REPLACEMENT PARTS LIST

KEY NO. PART NO. NAME: DESCRIPTION/ QTY PER MACH.

1	H-391	Silver Saver Scrapping Ring	1
2	G-554	Neoprene Connector Sleeve	1
3	A-3000	Stainless Steel Clamps	2
4	G-556	Chamber	1
	G-299	Offset Chamber	1
5	A-4100	Screw: Hxhd 3/8-24x1-3/4	6
6	08-BC-312	Washer: Lock Split 5/16	6
7	10-5-27.	Pipe Plug: 1/2"	1
8	D-158	Gasket: Offset Adaptor	1
9	D-162	Offset Adaptor Plate	1
10	D-056	Neoprene Offset Adaptor	1
11	B-500	Gasket: Sizing Ring	1
12	D-1272	Sizing Ring	1
13	B-011	10" Buna Sizing Ring "O" Ring	1
14	A-4200	Screw: Center Breaker	1
15	A-1288	Center Breaker	1
16	A-1022	Gasket: Center Breaker	1
17	A-4201	Roll Pin	1
18	D-1287N	Rotor	1
19	D-1009	Lip Seal "Rotor"	1
20	A-1011	Lip Seal "Motor Shaft"	2
21	A-4202	Screw: Seal Housing	4
22	D-1008	Seal Housing	1
23	A-019	Gasket: Seal Housing	1
24	G-247	Bowl	1
25	A-4120	Screw: 7/16-20x1 S.H.C.S.	2
26	A-159	Discharge Flange	1
27	A-161	Gasket: Discharge Flange	1
28	A-016	Slinger " Motor Shaft"	1
29	09-BC-927	Leg Assy w/Foot: 2" X 9-5/8", SS	3
30	A-1185	Key	1
31	A-2213	Screw: Motor Mounting	4

KEY NO. PART NO. NAME: DESCRIPTION/ QTY PER MACH.

MOTOR OPTIONS

32	P-0335060	Motor: 3HP/3PH/50 & 60HZ	1
	P-0535060	Motor: 5HP/3PH/50 & 60HZ	1
	02-ABC-723	Motor: 7.5 HP/3PH/60HZ	1
	02-ABC-103	Motor: 10 HP/3PH/60HZ	1

NOT SHOWN

02-BC-402	Bearing: #207 UPPER	1
02-BC-401	Bearing: #206 LOWER	1
B-SGK-NS	Seal and Gasket Kit (Includes 11, 13,16,19,(2)20,23,27, Grease)	1
B-CRK-NS	Complete Renewal Kit (Includes (6)5, 11,12, 13,14,15,16,18,19,(2)20,23,27, Grease)	1

RAC1 REPLACEMENT PARTS LIST

KEY	PART NO.	NAME: DESCRIPTION	KEY	PART NO.	NAME: DESCRIPTION
1	03-5-988	Pushbutton Assy: Red (N.C.)	13	08-5-949	Screw, Php HD, 10-32 x 1/2
2	03-5-987	Pushbutton Assy: Black (N.O.)	14	03-5-983	Back Plate: RAC1 & 2
3	03-5-1023	Legend Plate: "STOP"	15	03-5-1067	Track: Contactor Mounting
4	03-5-1025	Legend Plate: "RUN"	16	03-5-1097	Grounding Lug
5	03-5-1042	Enclosure: Non-Metallic, RAC1 & 2	17	03-5-1002	Terminal Strip: 9 Position
6	03-5-1034	Control Module		03-5-1001	Terminal Strip: 6 Position
7	08-6-258	Screw: Php HD, 8-32 x 1		03-5-1085	Terminal Strip: 13 Position
8	03-5-1000	Wiring Harness: RAC1	18	08-6-251	Screw, Php HD, 8-32 x 3/4
9	03-HAB-940	Fuse: 2.5 Amp	19	03-5-1124	Overload Relay: 3-12 Amp
10	03-HAB-995	Transformer: 24V/115, 230V 50VA		03-5-1125	Overload Relay: 11-16 Amp
	03-HAB-911	Transformer: 24V/208, 230, 460V 50VA		03-5-1126	Overload Relay: 18-25 Amp (Use with 7L)
	03-HAB-912	Transformer: 24V/380V 50VA		03-5-1127	Overload Relay: 22-32 Amp (Use with 10L)
11	08-6-250	Screw: Php HD, 8-32 x 1/2			
12	03-BC-907	Contactor: Rev, 25A, 24V, 50/60HZ			
	03-C-909	Contactor: Rev, 32A, 24V, 50/60HZ (7L & 10L)			

SPECIFY HP, VOLTAGE, PHASE, MODEL AND SERIAL NUMBER WHEN ORDERING CONTACTORS AND OVERLOAD RELAYS.

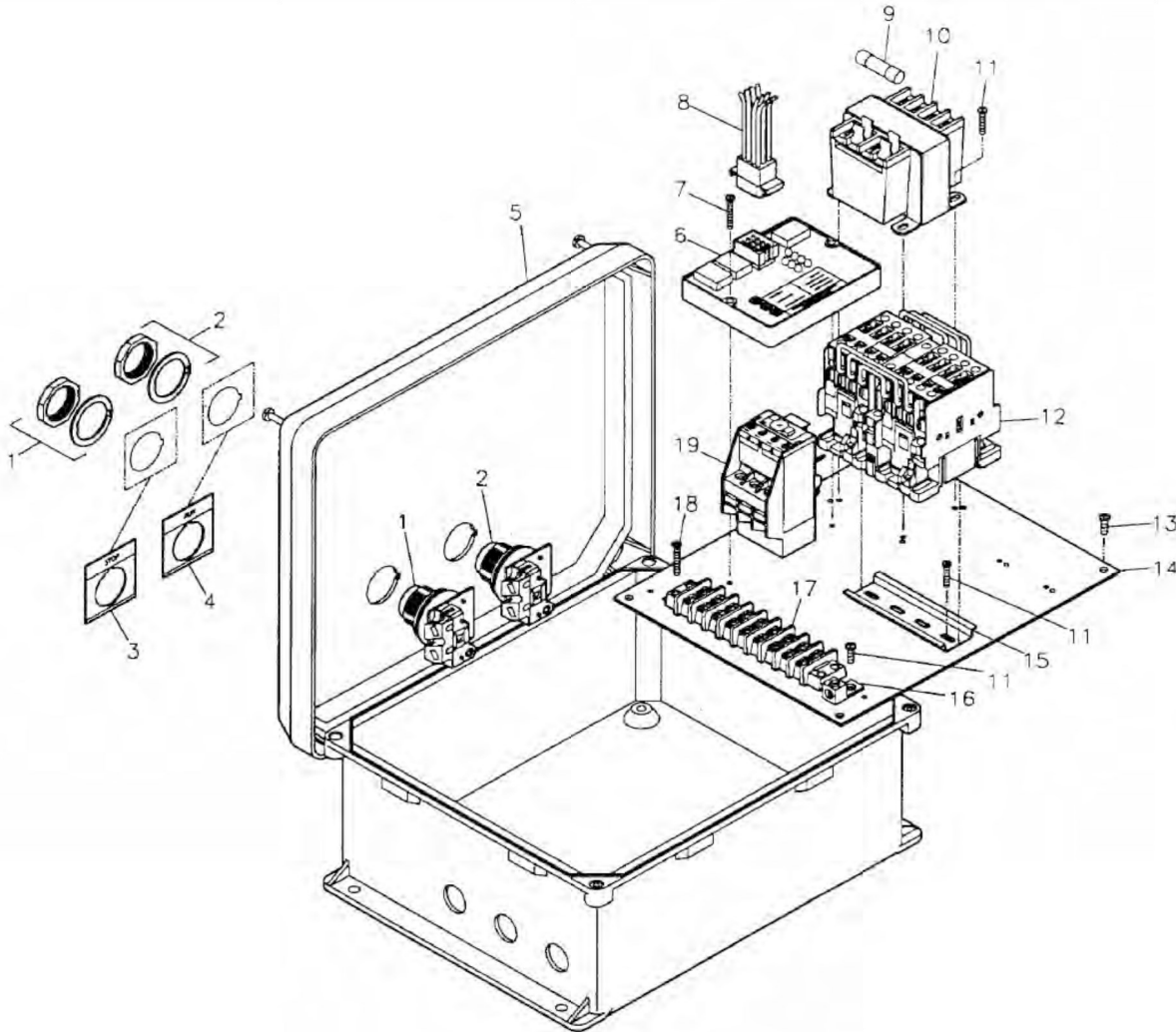

RAC2 REPLACEMENT PARTS LIST

KEY	PART NO.	NAME: DESCRIPTION	KEY	PART NO.	NAME: DESCRIPTION
1	03-5-1036	Pushbutton Assy: Lighted, Red	17	08-5-949	Screw, Php HD, 10-32 x 1/2
2	03-5-1037	Pushbutton Assy: Lighted, Amber	18	03-5-983	Back Plate: RAC1 & 2
3	03-5-1023	Legend Plate: "STOP"	19	03-5-1067	Track: Contactor Mounting
4	03-5-1025	Legend Plate: "RUN"	20	03-5-1097	Grounding Lug
5	03-5-1049	Handle: Disconnect Switch (w/Shaft)	21	03-5-1002	Terminal Strip: 9 Position
6	03-5-1042	Enclosure: Non Metallic, RAC1 & 2		03-5-1001	Terminal Strip: 6 Position
7	03-5-1034	Control Module		03-5-1085	Terminal Strip: 13 Position
8	08-6-258	Screw: Php HD, 8-32 x 1	22	03-5-1124	Overload Relay: 3-12 Amp
9	03-5-999	Wiring Harness: RAC2		03-5-1125	Overload Relay: 11-16 Amp
10	03-HAB-940	Fuse: 2.5 Amp		03-5-1126	Overload Relay: 18-25 Amp (Use with 7L)
11	03-HAB-995	Transformer: 24V/115, 230V 50VA		03-5-1127	Overload Relay: 22-32 Amp (Use with 10L)
	03-HAB-911	Transformer: 24V/208, 230, 460V 50VA			
	03-HAB-912	Transformer: 24V/380V 50VA			
12	08-6-250	Screw: Php HD, 8-32 x 1/2			
13	03-5-1120	Shaft: Disconnect Switch, RAC2			
14	08-6-251	Screw, Php HD, 8-32 x 3/4			
15	03-5-1041	Disconnect Switch: 40 Amp, RAC2			
16	03-BC-907	Contactor: Rev, 25A, 24V, 50/60HZ			
	03-C-909	Contactor: Rev, 32A, 24V, 50/60HZ (Use w/ 7L & 10L)			

SPECIFY HP, VOLTAGE, PHASE, MODEL AND SERIAL NUMBER WHEN ORDERING CONTACTORS AND OVERLOAD RELAYS

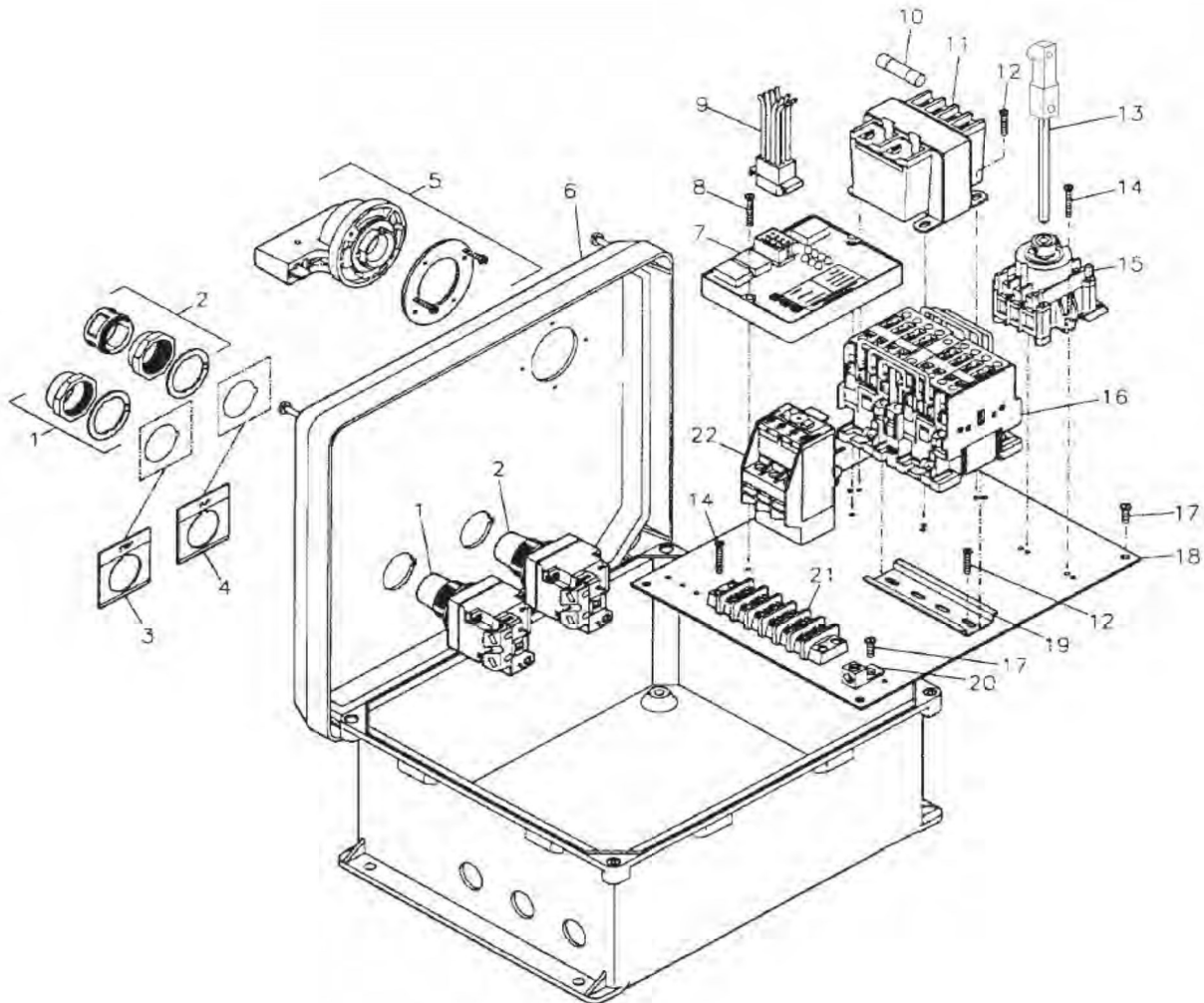

TERMS OF SALE

1. NATURE OF DOCUMENT. This document constitutes the acceptance of the Master Disposers Division of Somat Company ("Seller") to sell the products specified on the reverse side (the "Products") on the terms and conditions contained herein, however, acceptance is made expressly conditional on the Buyer's agreement to all of the terms and conditions contained herein. Seller's acceptance of a purchase order from the Buyer shall not constitute acceptance of any of the terms and conditions thereon which differ from these terms, except as the Seller may otherwise specify in writing.

2. TERMINATION AND CANCELLATION. Seller shall have the right to terminate and cancel the contract for sale of the Products at any time Seller determines that Buyer's credit is not satisfactory. Any such termination or cancellation shall be effective upon notification (orally or in writing) to Buyer and shall be without liability to the Seller. Under no circumstances shall Buyer have the right to terminate the contract or cancel its order to purchase the Products, without written authorization by the Seller. All cancelled orders and returned goods will be subject to a minimum of 25% cancellation and/or restocking charge. Custom or modified units cannot be returned.

3. PRICES. Unless otherwise indicated, prices are F.O.B. Lancaster, PA and do not include any sales, use, excise or similar taxes or duties now or hereafter imposed. Errors or omissions in prices are subject to correction.

4. PAYMENT. Unless otherwise indicated, payment terms are net cash 30 days from date of shipment. In the event that the Buyer fails to make payment on time, Buyer shall be liable to Seller for the lesser of (a) 1.5% per month on the remaining balance or (b) the highest monthly interest rate which may lawfully be charged to Buyer. Buyer shall be liable for all expenses (including reasonable attorneys' fees) incurred by Seller in collecting or attempting to collect any amounts due to Seller under the contract.

5. TITLE; RISK OF LOSS. Title to, and risk of loss of, the Products shall pass to Buyer upon the delivery of the Products F.O.B. Lancaster, PA to an agent of Buyer or to a common carrier.

6. INSPECTION. If, upon receipt of the Products by Buyer at the destination, the same shall appear not to conform to the order, Buyer shall within seven (7) days after receipt thereof, notify Seller of such condition and afford Seller a reasonable opportunity to inspect the Products and make the appropriate adjustments, repair or replacement. The remedies afforded under Section 7 below shall be exclusive for any defects discovered in the Products and which could have been discovered upon inspection. If the Seller is not so notified, the Buyer waives any recourse for those defects, and all warranty obligations of Seller regarding such obvious defects or deficiencies shall terminate.

7. LIMITED WARRANTIES AND REMEDIES. Seller warrants that, at the time of shipment, the Products will be free from defects in material and workmanship for a period of one year from the date of purchase by the initial user. Written notice of a claim under this warranty must be received by Seller before the expiration of such period in order for warranty coverage to apply.

If notice of a claim is timely made, Seller will repair or replace the Product or part which is defective (at Seller's sole option) either at the user's facility or at Seller's plant, as Seller shall decide. If Seller decides that a Product or part should be returned to its plant, the Buyer or user shall have the following obligations:

- removal of any parts to be returned;
- identification of all parts with tags stating the model number and serial number of the Products on which the part is used;
- shipment of Products and/or parts, transportation prepaid, to Seller's plant;
- installation of the repaired or replaced Product or parts at user's facility.

This Warranty shall not apply to the extent that Products or parts have been used other than in conformance with operating or maintenance instructions, subjected to misuse or abuse, damaged by accident, act of God, abnormal use or stress or any other matter unrelated to Seller and beyond its reasonable control or altered or modified by third parties.

THIS WARRANTY IS EXCLUSIVE AND IS IN LIEU OF ALL OTHER WARRANTIES, EXPRESS OR IMPLIED, INCLUDING THE IMPLIED WARRANTIES OF MERCHANTABILITY AND FITNESS FOR PURPOSE. IN NO EVENT SHALL THE COMPANY BE LIABLE FOR LOSS OF USE, REVENUE OR PROFIT OR FOR ANY OTHER INCIDENTAL, SPECIAL OR CONSEQUENTIAL DAMAGE INVOLVING THE PRODUCTS.

8. LIMITATION OF LIABILITY. The liability of Seller arising out of the manufacture, sale, delivery, repair, or use of any of the Products shall not, in any event, exceed the cost of correcting defects or making replacement as required in the Limited Warranty and, upon the expiration of the Limited Warranty, all liability of Seller to Buyer shall terminate.

9. DELAYS. Neither party shall be liable for any delay or failure to perform any obligation to the other if such delay or failure shall be caused by an event or contingency beyond its reasonable control, irrespective of the nature thereof, however, the delaying party shall endeavor to correct such delay as soon as reasonably practicable.

10. MODIFICATION; ASSIGNMENT; APPLICABLE LAW; ENTIRE AGREEMENT. No modification of the terms and conditions specified in the contract shall be binding upon Seller unless agreed to by Seller in writing. The contract shall not be assigned by Buyer, nor may any of the duties of Buyer there under be delegated, without the written consent of Seller. Any such assignment or delegation without such consent shall be void. The contract shall be governed by, and construed in accordance with, the laws of the State of Pennsylvania. The provisions of the contract shall constitute the entire agreement of the parties with respect to the sale of the Products by Seller to Buyer and shall supersede all prior discussion and writings between the parties.

11. BINDING EFFECT OF CONTRACT. The contract shall be binding upon, and shall inure to the benefit of, the parties hereto and their respective successors and assigns.

12. RETURNS. No returns will be accepted without the prior approval of the Seller. A Return Authorization Number must be given by Seller prior to Products being shipped, freight prepaid, by Buyer. Any damage in transit to Products being returned is Buyer's responsibility.

All accepted returns are subject to a 25% or \$25.00 minimum restocking charge. Returns that have been approved by Seller must be received within thirty (30) days after approval. Returns will not be considered after ninety (90) days from date of original notice.

13. INDEMNITY. Buyer agrees to indemnify, hold harmless and defend Seller from and against any and all liabilities and expenses arising out of any injury or damage which results from Buyer's use, misuse, misapplication, failure to inspect, maintain or repair the Products which are the subject of this agreement.

14. MINIMUM ORDER. \$75.00 net.

WARRANTY

THE EXCLUSIVE ONE AND TEN YEAR WARRANTY

All products (and parts) manufactured and sold by MASTER DISPOSERS (the "Manufacturer") are warranted to be free from defects in material and workmanship for a period of one year following the date of its initial installation or from the date of shipment from the factory or factory warehouse, whichever expires first. Notice of a claim under this Warranty must be received by the Manufacturer at its offices before the expiration of such period in order for Warranty coverage of **PARTS AND LABOR** to apply.

If notice of a claim is timely made, the Manufacturer will repair or replace the product or part which is defective either at the user's facility or at the Manufacturer's plant, as the Manufacturer shall decide. In addition, the Manufacturer warrants that the basic body components of every Master Disposer will remain serviceable for a period of at least **TEN YEARS**. Should any of these basic body components require replacement during the first ten years of normal usage following installation the Manufacturer will furnish new duplicate parts to the original user at no charge. Manufacturer cannot warrant products returned to the factory not properly packaged, causing additional damage.

This Warranty shall not apply to the extent that products or parts have been used other than in conformance with operating and maintenance instructions, subjected to misuse or abuse or damage by accident, act of God, abnormal use or stress or any other matter unrelated to the Manufacturer, and beyond its reasonable control or otherwise altered or modified by third parties. In addition, this Warranty does not cover normal wear items, such as sizing rings, impact bars and rotors. **THIS WARRANTY IS EXCLUSIVE AND IS IN LIEU OF ALL OTHER WARRANTIES, EXPRESSED AND IMPLIED, INCLUDING THE IMPLIED WARRANTIES OF MERCHANTABILITY AND FITNESS FOR PURPOSE.** In no event shall the Manufacturer be liable for loss of use, revenue or profit or for indirect or consequential damages.

All Master machines are packed in heavy corrugated shipping containers suitable for reshipment.

Master Disposers is not responsible for any typographical errors.

Due to continued product improvement specifications are subject to change without notice.

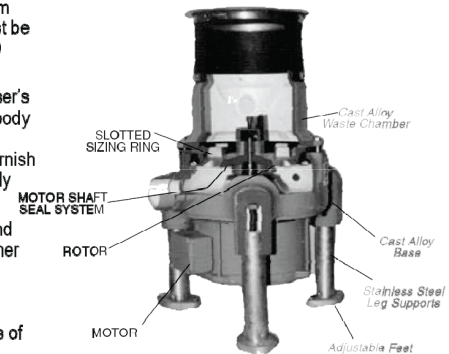

STANDARD ONE YEAR WARRANTY
ALL MASTER disposer components, shown above in BLOCK print, are guaranteed against all defects for the initial ONE YEAR period of use, as stated in the Warranty.

TEN YEAR WARRANTY
ALL MASTER basic body components, shown above in italicized print, are guaranteed to remain serviceable at least TEN YEARS as stated in the Warranty.