



# DH-100w

## WASTE DEHYDRATOR



The **Somat DH-100** is a waste management system that processes waste for medium to large foodservice facilities and institutions. Compostable waste is dehydrated using an energy efficient and automated process. The **DH-100** is easy to install, maintain and requires no fresh water connection. Paddles macerate the waste heated by the unit's storage chamber to kill any bacteria and reduces the waste matter by up to 93%, producing a dry, earthy material that may be used as an accelerant in a composting process. Somat's patented Dryness Sensing Technology allows for proper processing time regardless of batch size. Combine with a Somat Pulper for a complete waste management system.

### STANDARD FEATURES

- 304 stainless steel construction with polished exterior
- Mechanical agitation
- Insulated chamber oil jacket
- Sealed inlet and output doors
- Agitator stops when door is open
- Stand alone, portable design
- 50-220 lb. input capacity
- 8-18 hour treatment time depending on load size
- One touch fully automatic controls
- Condensate drain line provided
- Patented dryness sensing technology

### OPTION

- Self greasing bearings
- Cold weather package – Allows the dehydration process to occur at temperatures down to 15°F; consult factory for details

### VOLTAGE OPTIONS

- 208V 60cy 3ph
- 220V 60cy 3ph
- 480V 60cy 3ph
- International options available

### BENEFITS

- 83-93% waste reduction
- Designed for medium to large scale facilities
- No enzymes or additives required
- Low labor cost, one person operation
- Low maintenance
- No fresh water connection
- Recycles heat energy
- Processes food waste and compostable disposables
- Reduces/eliminates hauling costs

**The Power to Transform WASTEFUL to SUSTAINABLE**

# DH-100w

## WASTE DEHYDRATOR



DH-100	
POWER SUPPLY	MINIMUM SUPPLY CIRCUIT CONDUCTOR AMPACITY
208-220V/3Ø/60Hz	30A
440-480V/3Ø/60Hz	15A

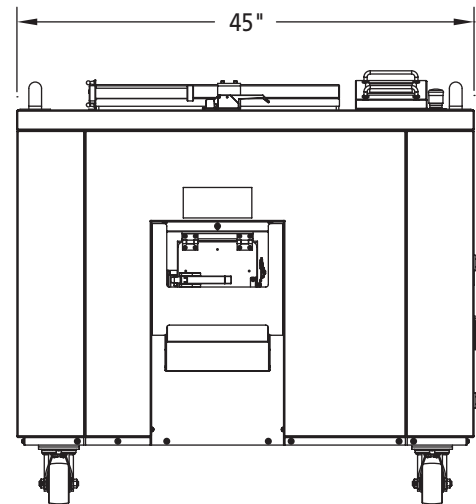
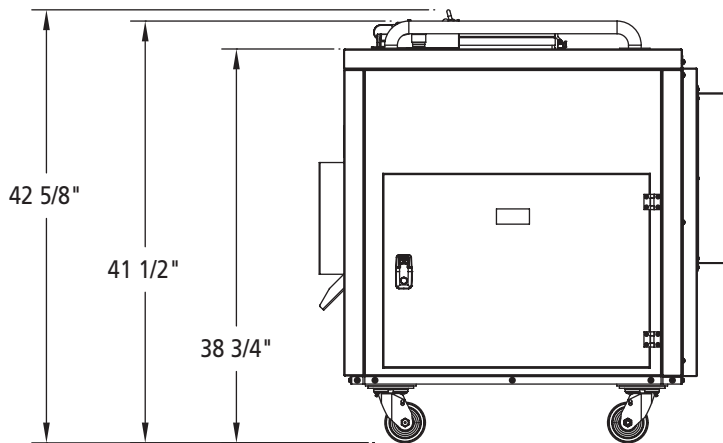
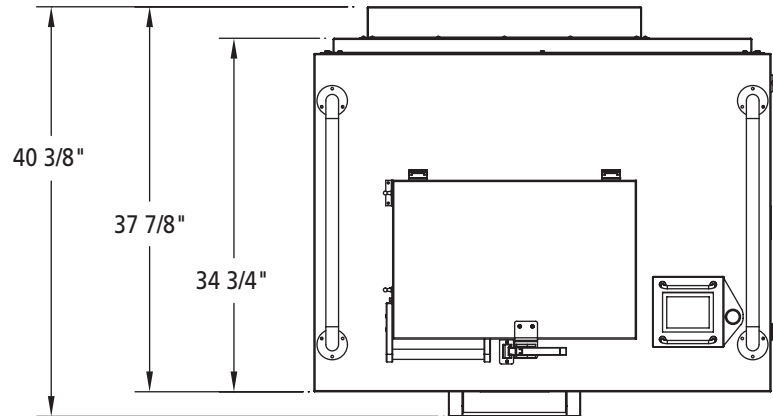

### DH-100 SPECIFICATIONS

Processing Method	Multi-stage indirect heat & dry dehydration process
Design Type	Stand-alone, portable design 304 stainless steel construction
Input Capacity (lbs.)	50 - 220 lbs.
Treatment Time	8 - 18 hrs.
Average Reduction Rate	83% - 93%
Power (Electricity)	Three-phase, 30/15Amp / AC 200-240/480v * 50Hz/60Hz
Power Consumption	4.0 kw
Dimension (W x D x H)	45" x 37.5" x 44.5"
Shipping Dimension/Weight	55" x 49" x 56" Weight: 1,025 lbs.
Safety Feature	The internal agitator automatically stops when the hopper door is open
Heating Method	Indirect multi-stage heat & air recirculation
Automated Control	One-touch smart control panel UL Listed
Treatable Items	Food waste and compostable disposables
Warranty	1 year manufacturer's standard warranty

*In line with its policy to continually improve its products, Somat reserves the right to change materials and specifications without notice.*