

ILLUSTRATED PARTS BREAKDOWN

PURPOSE:

The Illustrated Parts Breakdown in each section provides information on components, assemblies and detail parts for identification, determination of needed replacement parts and an illustration of assembly and disassembly relationships.

GROUP ASSEMBLY PARTS LIST:

The Group Assembly Parts List consists of those components, assemblies and detail parts which comprise the specific piece of equipment. Each assembly listed is followed immediately by its detail parts, properly indented thereunder to show their relationship to the assembly; for example, a part listed under indenture "2" is a component of the assembly listed under indenture "1" immediately above it. Items used to attach parts or assemblies to each other designated "(ATTACHING PARTS)" and are listed immediately following the item or items they attach: The symbol ---*--- denotes the end of attaching parts. The quantity required or "REQ" column lists the quantity of the item required in one assembly of which it is a component. It is, therefore, not necessarily the total quantity of the part required in the complete equipment. Items indicated by an asterisk (*) in the "REQ" column *are recommended spare parts to be kept on hand by the customer*. The term "Ref", if required, denotes that the assembly has been previously listed in the breakdown and at that point reflected the quantity required. The 5-digit numbers shown in parenthesis (00000) are SOMAT[®] part numbers and *should be used when ordering parts*.

PARTS ORDERING INFORMATION:

Include the following information when ordering parts.

1. The correct, complete description of the part required
(See Group Assembly Parts List.)
2. The serial number of the unit on which the part is to be used.
3. Complete shipping instructions.

The above information will help expedite the delivery of your needed parts.
When ordering spare or replacement parts, direct the above information to:

**SERVICE DEPARTMENT
SOMAT COMPANY
165 INDEPENDENCE COURT, LANCASTER, PA 17601
Telephone 714-397-5100 * Fax 717-291-0877
1-800-23-SOMAT (1-800-237-6628)
parts@somatcompany.com**

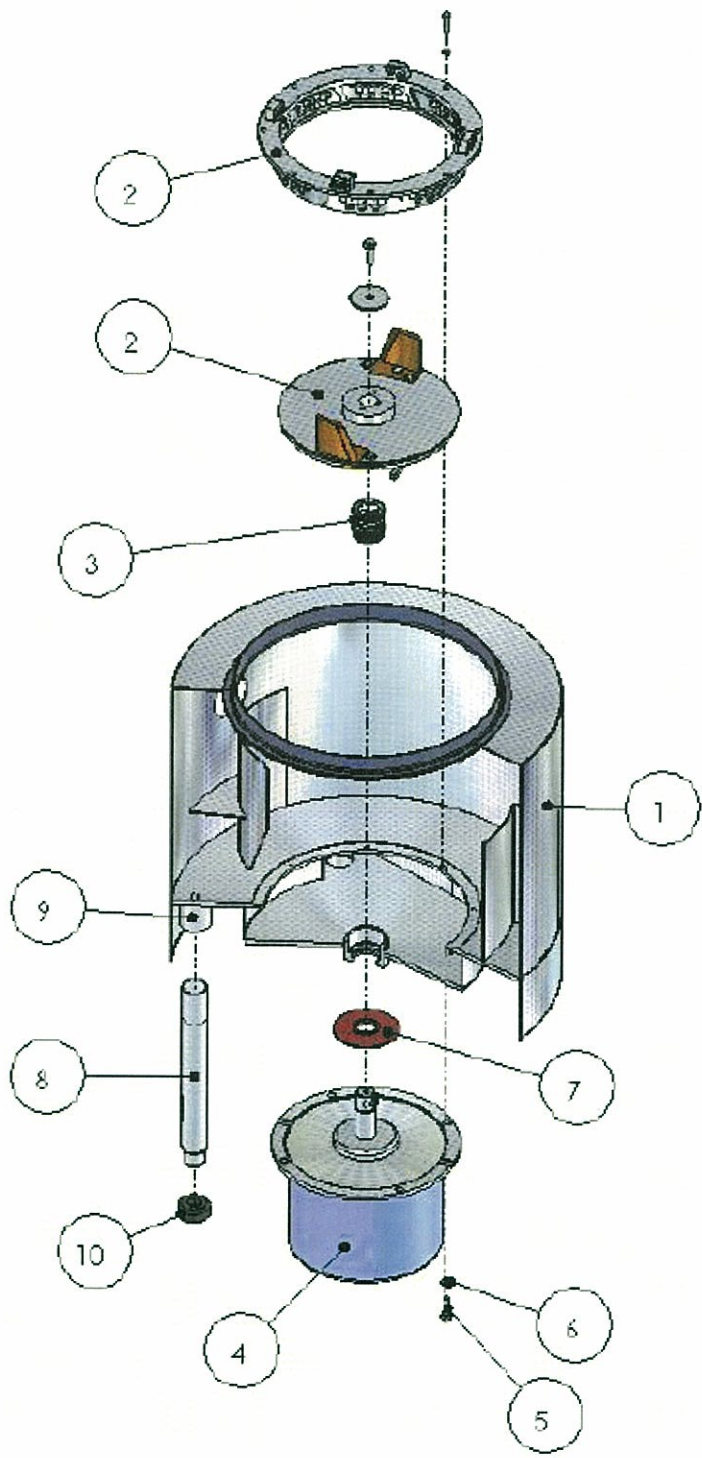

FIGURE 2. SPC-75S PULPER, EXPLODED VIEW

FIG. & ITEM	DESCRIPTION	REQ.
2-	PULPER ASSEMBLY MODEL SPC-75S	
-1	SHELL AND SLURRY CHAMBER ---*---	1
-2	CUTTING MECHANISM: <u>SEE CUTTING MECHANISM SECTION</u> ---*---	1
-3	SEAL, Mechanical Ni-Resist (54325)	1*
-4	MOTOR, 7-1/2 HP, TEFC (41734* Tapered Shaft)(41734* Straight Shaft) (ATTACHING PARTS)	1
-5	SCREW, Hex Hd., 7/16-14 X 1" Lg., Cad. Pl.	4
-6	LOCK WASHER, 7/16 I.D., Split Type, Cad. Pl. ---*---	4
-7	FLINGER, Drive Motor (32460)	1
-8	LEG, Adjustable (39705) (ATTACHING PARTS)	4
-9	SET SCREW, Socket, 1/4"-20 X 3/8" Lg., Cad. Pl.	6
-10	VIBRATION ISOLATOR, Rubber (16200)	4
	ITEMS NOT SHOWN:	
	HIGH TANK ONLY	
	Lid Latch, Over Center (35100)	1
	Lid Hinge (35613)	1
	Limit Switch, Magnetic Prox (54999-1)	1*
	Hi Energy Magnet (55005)	1*
	UDT ONLY	
	UDT Lid (84771)	1
	UDT Gasket (34000)	1
	UDT Cone (57315)	1
	Limit Switch, Magnetic Prox. (59942&59943)	1*
	Pipe Cap, Square, 1/2" NPT, 316 S/S (20469)	1
	Nipple, 1/2" NPT x 4" lg., 316 S/S (43041)	1
	Elbow, 1/2" NPT, 316 S/S (26850-1)	1
	TRAY ONLY	
	Curtain (SPECIFY SIZE)	1
	Tray Gasket (33915)	1
	TROUGH ONLY	
	Trough Gasket (82781)-9"	1
	Trough Gasket (82780)-12"	
	OPTIONAL ITEMS:	
	Dam (81880)	1
	SPECIAL TOOLS:	
	Impeller Puller (84150)	1
	Seal Installation Tool (89711)	1

* Recommended Spare Parts

**COMPONENT LIST
& ITEM NO'S.**

DESCRIPTION

REQ.

3- *PIPING COMPONENTS FOR SPC-75S PULPER*

SPC-75S FRESH WATER ASSEMBLY

-1	Gate Valve, 3/4" (64804)	1
-2	Backflow Preventor, 3/4" (11311)	1*
-3	Shock Arrestor, 3/4" (11300)	1
-4	Solenoid Valve, 3/4" (64715)	1*

SPC-75S DRAIN ASSEMBLY

-5	Drain Valve, 2" (64840)	1
----	-------------------------	---

SPC-75S RETURN WATER ASSEMBLY

-6	Gate Valve, 1-1/2" (64825)	1
-7	Gate Valve, 1" (64805)	variable

SPC-75S OVERFLOW

-8	Bushing, 1-1/2" X 1" (51650)	1
-9	Bushing, 1" X 3/4" (51645)	1